

**Carbon Nanofibers as a Hydrogen Storage Medium for Fuel Cell
Applications in the Transportation Sector**

**Robert Zeches
December 4, 2002**

**Submitted in partial fulfillment of course requirements for MatE 115, Fall 2002
Instructor: Professor G. Selvaduray**

Table of Contents

Introduction.....	1
The Benchmark	1
Safe and Efficient Hydrogen Storage	1
Principle.....	3
Fuel Cells.....	3
Carbon Nanofibers	4
Application.....	9
The Carbon Nanofiber Hydrogen Fuel Tank	9
Conclusion.....	11
References	12

Introduction

The Benchmark

In the push to replace fossil fuels and their conversion into energy via the internal combustion engine with cleaner and more renewable energy sources for the transportation sector, hydrogen and the fuel cell have emerged as the best candidates for the future.

Hydrogen is readily available in near limitless quantities and produces only water and heat as a byproduct when reacted with oxygen. While hydrogen can be generated on-board a vehicle by reforming methanol or other hydrocarbons, a cleaner approach is to store pure hydrogen on-board the vehicle without any reforming process required. In an obvious acknowledgement of this and in pursuit of the goal to reduce the country's dependence on fossil fuels and migrate to a hydrogen energy base for the transportation sector, the U.S. Department of Energy (D.O.E.) has set the benchmark for on-board hydrogen storage systems at 6.5wt.% [1]. (For the purposes of this paper and its references, wt.% or "weight percent", refers to the ratio of stored hydrogen weight to total storage system weight.)

Safe and Efficient Hydrogen Storage

The challenge in using fuel cells with an on-board supply of hydrogen in automotive applications is ensuring that the hydrogen storage system is safe as well as light enough to not adversely affect the efficiency benefits of using a fuel cell in the first place. In pursuit of the D.O.E. benchmark of 6.5wt.%, many hydrogen storage systems for automotive applications have been investigated, the most notable of which are compressed hydrogen gas, liquid hydrogen, chemical storage in chemical and metal hydrides and gas-on-solid physical adsorption [1]. The first three of these methods have been explored extensively and all have their shortcomings. Besides the safety concerns due to the pressures involved, compressed

hydrogen gas storage suffers due to the permeability and embrittlement of the metal tanks, the high amount of energy required to pressurize the gas, and a maximum 2wt.% storage capacity with conventional storage tanks and 5wt.% using more expensive carbon fiber-wrapped polymer tanks [1]. Liquid storage systems are safer than gas storage systems due to lower pressure requirements, but have the potential for losses through evaporation and require a significant amount of energy and insulation to keep the hydrogen in a liquid state [1]. Metal hydride storage systems are also safer than compressed gas systems, but to date these systems have only been reproducibly shown to exhibit a ceiling of 3wt.% at ambient temperatures and thus fall short of the D.O.E. benchmark, however research continues and the technology could still show promise [1,2].

The fourth approach, gas-on-solid adsorption, has been investigated in recent years using carbon nanostructures, the most promising of which are carbon nanofibers, and is proving to be a viable solution. Gas-on-solid physical adsorption is a process by which a gaseous substance condenses on the free surfaces of a solid. Since the process involves weak molecular forces, such as the Van der Waals force, it is generally reversible with minimal energy input. Carbon is already a well-known and well-established industrial adsorbent because it presents a high surface area to weight ratio, and it is this quality of carbon that has generated so much interest in it as a hydrogen adsorbent. Recent reproducible studies have shown that the potential for hydrogen storage on carbon nanofibers via physical adsorption reaches upwards of 15wt.%, more than doubling the D.O.E.'s target benchmark [3].

Principle

Fuel Cells

A simple example of a hydrogen fuel cell consists of an anode and a cathode with an electrolyte in-between that allows positive ions to pass through. Hydrogen fuel is fed to the anode and atmospheric oxygen is fed to the cathode. When activated by a catalyst, usually platinum on the cathode itself, the hydrogen atoms separate into electrons and protons, which take different paths to the cathode. The electrons take a path through an electrical circuit and load, while the protons take a path through the electrolyte. When the electrons and protons meet again at the cathode, they recombine along with the oxygen atoms to produce water and heat. This process is illustrated in Figure 1 below.

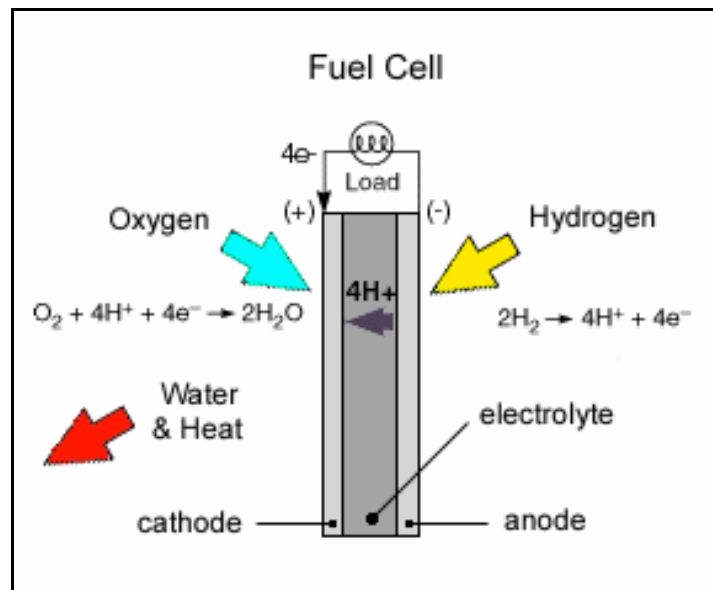

Figure 1. A simple fuel cell.

In order for a fuel cell to operate, it requires a constant supply of hydrogen. In transportation sector applications, this hydrogen must be stored locally in a safe and efficient manner. One method to do this that is proving to be viable and able to meet the D.O.E.

benchmark is that of a pressurized tank containing hydrogen physically adsorbed on carbon nanofibers.

Carbon Nanofibers

Carbon nanofibers consist of coil like fibers made up of very small graphite sheets that are stacked in specific configurations and separated by distances of 0.335 – 0.342 nm [4-6]. CNF are grown from the decomposition of carbon-containing gases such as hydrocarbons over metal or alloy surfaces which act as catalysts to the sheets' formation [4,5,7]. During the reaction, the carbon-containing gas molecules are adsorbed to certain faces of the catalyst's surface and are subsequently decomposed. Following this, the carbon atoms diffuse through the catalyst particle and precipitate at one or more other surfaces of the and form successive sheets that stack on one another to form the carbon nanofibers [4]. A scanning electron micrograph of typical carbon nanofibers can be seen in Figure 2 below [7].

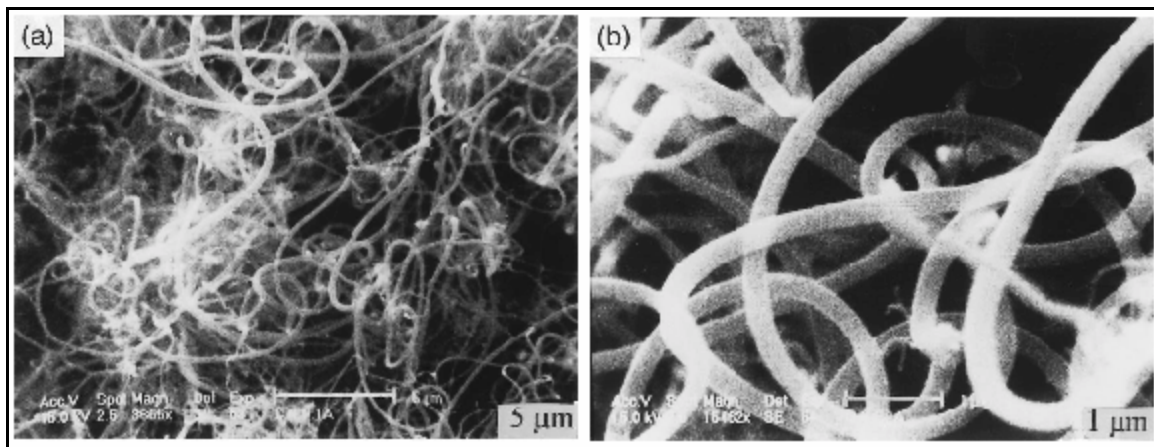

Figure 2. Representative scanning electron micrograph of carbon nanofibers prepared through cracking of acetylene gas; (b) is an enlarged section of (a). (From Gupta *et al.* [7]. © Elsevier Science.)

The typical lengths of the fibers are between 5 and 100 mm [4] and the diameters of them depend directly upon the size of the catalyst particles and are generally in the range of 5

to 500 nm [4,5,7]. Depending on the catalyst particle's composition and shape used in the reaction, the graphite sheets that make up the nanofiber organize into various configurations; the primary of which are herringbone, tubular (commonly called carbon nanotubes) and platelet configurations, as shown in Figure 3 below [4].

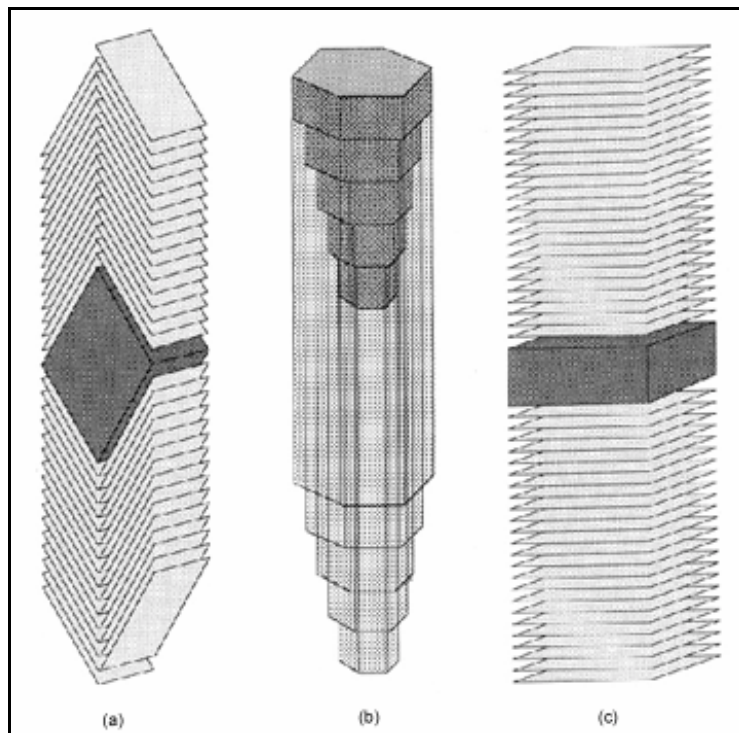

Figure 3. Schematic representation of the structural relationship between the catalyst metal and the precipitated graphite for three forms of carbon nanofibers: (a) herringbone, (b) tubular and (c) platelet. (From Rodriguez *et al.* [4]. © American Chemical Society.)

Hydrogen has a kinetic diameter of 0.289 nm, which is slightly smaller than the ~0.335 – 0.342 nm interlayer spacing in carbon nanofibers [6]. When prepared carbon nanofibers are placed in a vessel and exposed to hydrogen under pressures of 120-130 atm at room temperature, the hydrogen slips between the graphite sheets of the carbon nanofibers and adsorbs to surface of the carbon layers [3,4,6]. To prepare the carbon nanofibers for hydrogen adsorption, they are carefully pretreated to remove any metal impurities and

chemisorbed gases that may be present [3]. A schematic representation of the hydrogen adsorbing between the graphite sheets of a carbon nanofiber is illustrated in Figure 4 below [6].

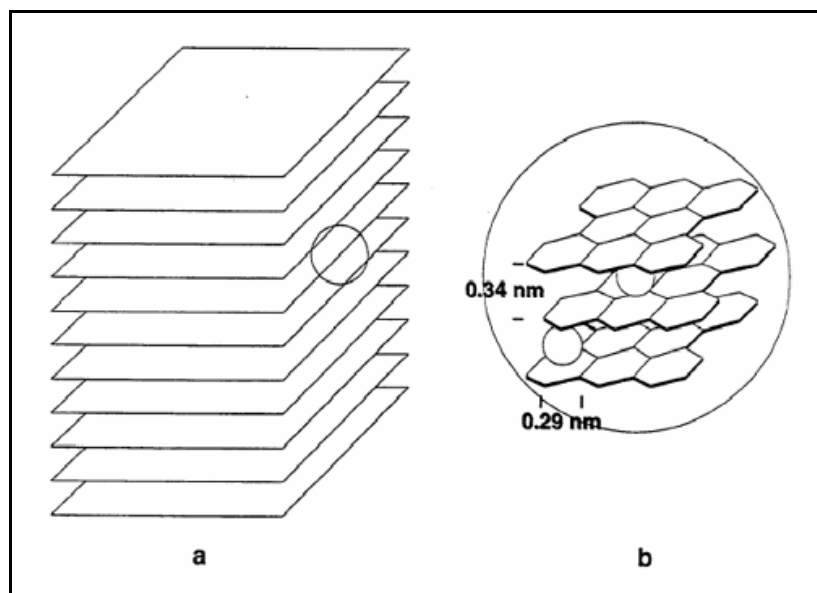

Figure 4. (a) Schematic representation of the structure of a carbon nanofiber; (b) enlarged section showing details of the hydrogen adsorption process. (From Park *et al.* [6]. © American Chemical Society.)

The adsorption rates that have been reproducibly measured at first seemed to exceed predictions of theoretical models of monolayer hydrogen adsorption [8]. However, it has been shown through X-ray diffraction and transmission electron microscope experiments that the interlayer spacing of the carbon nanofibers gradually increases as adsorption commences and at least a second layer of hydrogen forms on the first [3,6]. Additional theoretical calculations have confirmed that large amounts of hydrogen molecules between the sheets that make up a carbon nanofiber will in fact cause this separation [9]. This separation process continues and gradually levels off through successive adsorption/desorption cycles until a

maximum adsorption rate is attained [3]. This increase and leveling off of adsorption rates is illustrated in the P-C-T diagram shown in Figure 5 below [3].

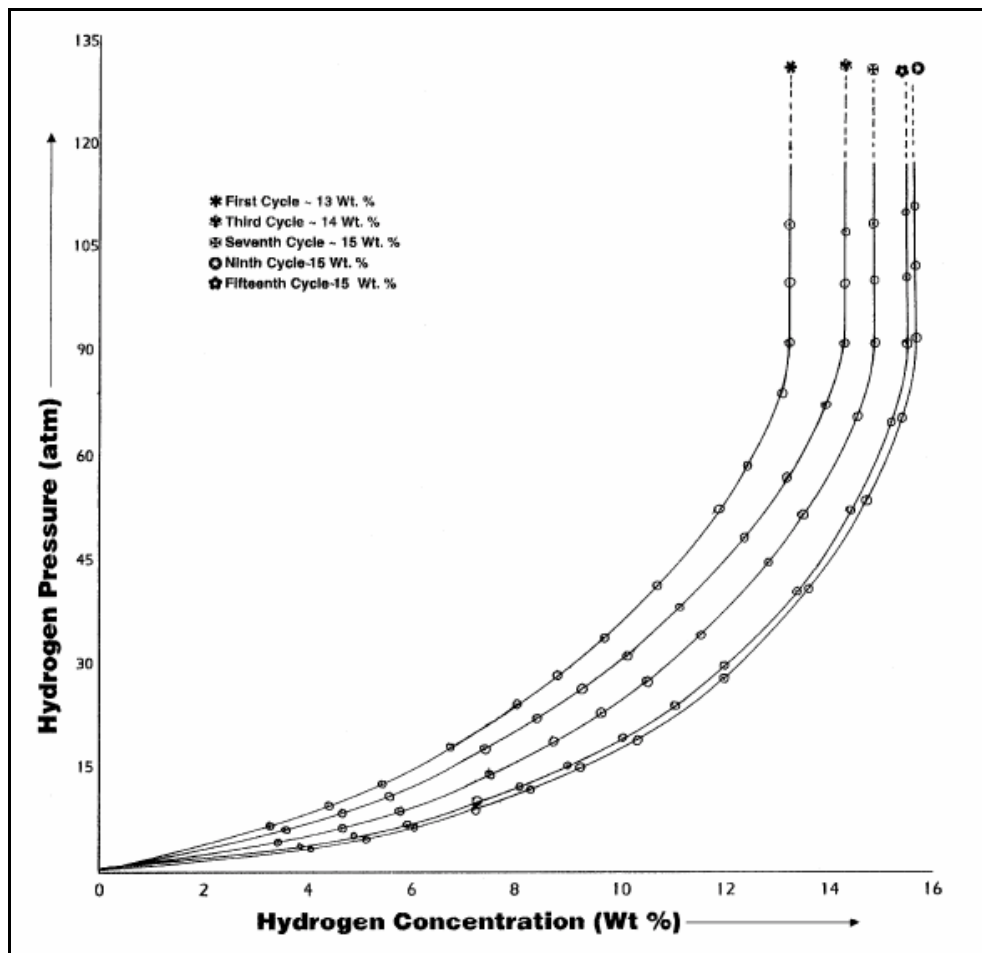

Figure 5. Representative P-C-T desorption curves revealing hydrogen storage capacity of graphite nanofibers as prepared from ethylene gas. The desorption curves bring out the maximum storage capacity of ~15wt.% at room temperature (~27°C). (From Gupta *et al.* [3]. © Elsevier Science.)

A hydrogen lattice parameter of 0.35 nm has been observed following the widening of the interlayer spacing of the carbon nanofibers and formation of subsequent layers of hydrogen [6]. Since this measurement is smaller than the measured bulk hexagonal close packed lattice parameter of 0.376 nm for hydrogen, it has been proposed that the unique structure of the carbon nanofibers suppresses the mobility of the hydrogen and causes it to

adopt an unusually highly packed state, which does much to explain the high storage levels that have been consistently measured [3,5,6].

Upon controlled release of the pressure, the hydrogen desorbs from the carbon nanofibers and is released as molecular hydrogen gas [5]. While the rate of adsorption is relatively slow, on the order of hours, adequately fast desorption rates of ~ 57 ml³/min have been reproducibly demonstrated [3]. Analysis of the discharged gas indicates that hydrogen is indeed the only component present and thus that there are no adverse reactions occurring between the carbon nanofibers or any impurities and the hydrogen throughout the process [5].

It should be noted that in determining the adsorbent capacity of the nanofibers it was discovered that not all of the adsorbed hydrogen is released in the desorption process at room temperature under atmospheric conditions [5]. This fraction of strongly held hydrogen that is retained has been attributed to a relatively small amount of chemisorption occurring, and has been confirmed through high temperature experiments on discharged carbon nanofibers using nitrogen and a thermal conductivity detector [5].

Application

The Carbon Nanofiber Hydrogen Fuel Tank

The principle application of a carbon nanofiber hydrogen storage medium is in a fuel tank for an integrated on-board fuel cell system with a polymer electrolyte membrane (PEM) fuel cell stack at its core and a hydrogen supply stored as adsorbed hydrogen in a pressurized tank containing carbon nanofibers. The PEM fuel cell is ideal for automotive applications because it operates at relatively low temperatures and can vary its output to meet varying power demands [1].

In this system, the hydrogen storage tank consists of a steel or composite tank or canister filled with vapor grown carbon nanofibers with adsorbed hydrogen present. The unused tank is kept pressurized at about 100-120 atm to maintain the adsorbed state of the hydrogen. The tank is connected to the fuel cell via a regulated pressure nozzle assembly controlled by the onboard computer that monitors the system. As the fuel cell demands hydrogen through the normal operation of the vehicle, the pressure in the fuel tank is decreased and gaseous hydrogen is released through the nozzle assembly and directed to the fuel cell cathode for catalysis and subsequent current generation. The rate of release is variable according to energy demands and can vary from zero to the maximum desorption rate available from the carbon nanofibers via incremental depressurization.

The D.O.E.'s target benchmarks for on-board hydrogen storage are based on a model hydrogen fuel cell powered vehicle to be able to travel 500 km without refueling and the metric that 3.1 kg of hydrogen would be required for a fuel cell powered car to travel those 500 km [1]. Based on the 10-15wt.% storage capability that has been demonstrated with properly prepared carbon nanofibers, as illustrated earlier in this paper, this would result in a

full tank of hydrogen adsorbed carbon nanofibers weighing between 21 and 31 kg with perhaps some additional weight required for the pressure valve and protective covering.

Based on these calculations resulting in particularly light fuel tanks full of hydrogen adsorbed on carbon nanofibers, and the fact that the adsorption process is much slower than the desorption process, it is suggested by the author that the concept of refilling the vehicle at a service station be abandoned for a process that involves the swapping of a nearly depleted tank for a full one. In this manner, refueling times will be reduced to the amount of time required to pull up to a hydrogen supplier, purchase a full tank, swap it with the nearly depleted one, and the return of the depleted tank to said supplier for refilling. In this manner, the long adsorption times are relegated to the supplier of the fuel and not to the consumer. Additionally, any wear or breakdown of the carbon nanofibers that may occur can be monitored and those units that have deteriorated beyond usefulness can be recycled.

Conclusion

Although there are differing opinions among the experts on the subject regarding the global supply of oil, even the most optimistic of them predict that the global production of conventional oil is likely to peak sometime between 2010 and 2020 [10]. If we are to be prepared for this inevitability we must accelerate our adoption of alternative fuels so we are at least prepared to meet the challenge when it arises. With its ubiquity in the universe and on our planet and its potential as one of the cleanest and most efficient fuel sources available to us, hydrogen is the obvious choice as our next basic source of energy, and the fuel cell is the obvious replacement for the internal combustion engine.

In order to usher in this new era of energy, many obstacles must be overcome and many new technological advances must be developed into viable solutions. One such application that has been demonstrated to have huge potential in this direction is that of carbon nanofibers as a hydrogen storage medium for fuel cells, particularly in the transportation sector. There is still a long way to go and much work to be done, but in this author's opinion it is time to begin the task of turning the positive results born of research into the viable solutions born of engineering.

References

1. U.S. Department of Energy, “A *Multiyear Plan for the Hydrogen R&D Program – Rational, Structure, and Technology Roadmaps*,” available at <http://www.eren.doe.gov/hydrogen/pdfs/bk28424.pdf>.
2. K.J. Gross, G.J. Thomas and G. Sandrock, “*Hydride Development for Hydrogen Storage*,” Proceedings of the 2000 Hydrogen Program Review, available at <http://www.eren.doe.gov/hydrogen/pdfs/28890dd.pdf>.
3. Bipin Kumar Gupta and O.N. Srivastava, “*Further studies on microstructural characterization and hydrogenation behavior of graphitic nanostructures*,” International Journal of Hydrogen Energy, **26**, 857-862 (2001).
4. Nelly M. Rodriguez, Alan Chambers, R. Terry K. Baker, “*Catalytic Engineering of Carbon Nanostructures*,” Langmuir, **11**, 3862-3866 (1995).
5. Alan Chambers, Colin Park, R. Terry K. Baker and Nelly M. Rodriguez, “*Hydrogen Storage in Graphite Nanofibers*,” Journal of Physical Chemistry B, **102**(22), 4253-4256 (1998).
6. C. Park, C.D. Tan, R. Hildalgo, R.T.K. Baker and N.M. Rodriguez, “*Hydrogen Storage in Graphite Nanofibers*,” Proceedings of the 1998 U.S. D.O.E. Hydrogen Program Review, available at <http://www.eren.doe.gov/hydrogen/pdfs/25315cc.pdf>.
7. Bipin Kumar Gupta and O.N. Srivastava, “*Synthesis and hydrogenation behavior of graphite nanofibers*,” International Journal of Hydrogen Energy, **25**, 825-830 (2000).
8. V. Meregalli, M. Parrinello, “*Review of theoretical calculations of hydrogen storage in carbon-based materials*,” Applied Physics A, **72**, 143-146 (2001).

9. N. Jacobson, B. Tegner, E. Schröder, P. Hyldgaard, B.I. Lundqvist, “*Hydrogen dynamics in magnesium and graphite*,” *Computational Materials Science*, **24**, 273-277 (2002).
10. Jeremy Rifkin, “*The Hydrogen Economy*,” (Tarcher / Putnam, New York, 2002) p.31.