

Edited-10/11/2008

Week 2

Exercise 1(a)

Aim

- To understand the use of RTD temperature sensor
- To understand the use of Sub VI's
- To create a new sub VI

To complete this exercise, you will need the IC temperature sensor available on the BNC-2120, SCB-68, or DAQ Signal Accessory.

Front Panel

1. Select **File»New** to open a new front panel.
2. Create the thermometer indicator, as shown on the following front panel.

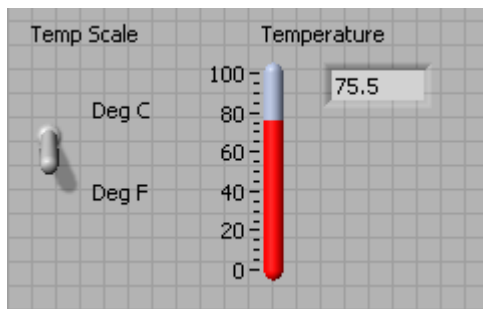

- a. Select the thermometer on the **Controls»Numeric Indicators** palette and place it on the front panel.
 - b. Type Temperature inside the label and click outside the label or click the **Enter** button on the toolbar.
 - c. Right-click the thermometer and select **Visible Items»Digital Display** from the shortcut menu to display the digital display for the thermometer.
3. Create the vertical switch control.
 - a. Select the vertical toggle switch on the **Controls»Buttons** palette.
 - b. Type Temp Scale inside the label and click outside the label or click the **Enter** button.

- c. Use the Labeling tool to place a free label, deg C, next to the TRUE position of the switch, as shown in the previous front panel.
- d. Place a free label, deg F, next to the FALSE position of the switch.

Block Diagram

4. Select **Window»Show Diagram** to display the block diagram.
5. Build the following block diagram.

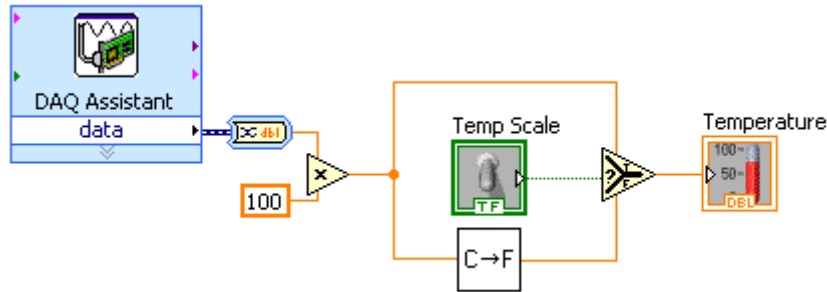

- a. Place the DAQ Assistant Express VI located on the **Functions»Input** palette. Make the following configurations in the DAQ Assistant configuration wizard.
 - i. Select **Analog Input** as the measurement type.
 - ii. Select **Voltage**.
 - iii. Select **ai0** as the channel from your data acquisition device.
 - iv. In the Task Timing section, select **Acquire 1 sample**.
- b. Place the Convert from Dynamic Data function located on the **Functions»Signal Manipulation** and select Single Scalar as the Resulting data type.
- c. Place the multiply function located on the **Functions»Numeric** palette. This function multiplies the voltage that the AI Sample Channel VI returns by 100.0 to obtain the Celsius temperature.
- d. Select **Functions»Select a VI**, navigate to the Convert C to F VI, which you built in Exercise 2a, and place the VI on the block diagram. This VI converts the Celsius readings to Fahrenheit.
- e. Place the Select function located on the **Functions»Comparison** palette. This function returns either the Fahrenheit (FALSE) or Celsius (TRUE) temperature value, depending on the value of **Temp Scale**.

- f. Right-click the y terminal of the multiply function, select **Create»Constant**, type 100, and press the <Enter> key to create another numeric constant.
- g. Use the Positioning tool to place the icons as shown in the previous block diagram and use the Wiring tool to wire them together.

Tip To identify terminals on the nodes, right-click the icon and select **Visible Items»Terminal** from the shortcut menu to display the connector pane.

6. Display the front panel by clicking it or by selecting **Window»Show Panel**.
7. Click the **Continuous Run** button, shown at left, to run the VI continuously.
8. Put your finger on the temperature sensor and notice the temperature increase.
9. Click the **Continuous Run** button again to stop the VI.
10. Create the following icon, so you can use the Temperature VI as a subVI.

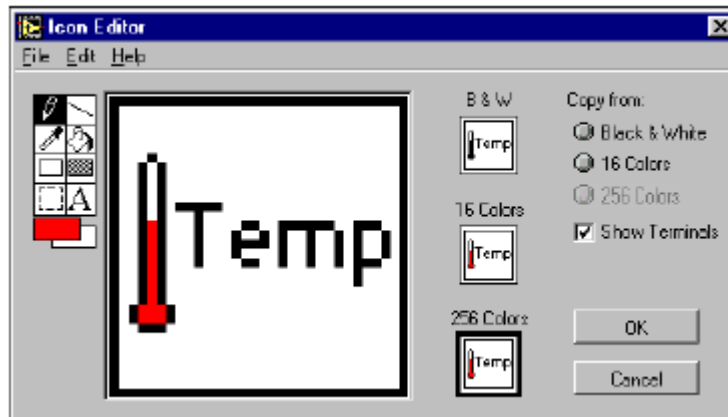

- a. Right-click the icon in the upper right corner of the front panel and select **Edit Icon** from the shortcut menu. The **Icon Editor** dialog box appears.
- b. Double-click the Select tool on the left side of the **Icon Editor** dialog box to select the default icon.
- c. Press the <Delete> key to remove the default icon.
- d. Double-click the Rectangle tool to redraw the border.
- e. Use the Pencil tool to draw an icon that represents the thermometer.
- f. Use the Foreground and Fill tools to color the thermometer red.

Note To draw horizontal or vertical straight lines, press the <Shift> key while you use the Pencil tool to drag the cursor.

- g. Double-click the Text tool, shown at left, and change the font to **Small Fonts**.
 - h. Select the **B&W** icon and select **256 Colors** in the **Copy from** field to create a black and white icon, which LabVIEW uses for printing unless you have a color printer.
 - i. When the icon is complete, click the **OK** button. The icon appears in the upper right corner of the front panel.
11. Select **File»Save** to save the VI. Choose a location on your hard drive and save the VI as Thermometer.vi.
 12. Select **File»Close** to close the VI.

End of Exercise

Week 2

Exercise 1(b)

Aim

- **To understand the use of shift registers**
- **To average the last three temperature measurements and display the same on the waveform graph.**

Front Panel

1. Open the Temperature Monitor VI, which you built in Exercise 4-1.
2. Select **File»Save As** and rename the VI Temperature Running Average.vi.

Block Diagram

3. Display the block diagram.
4. Right-click the right or left border of the While Loop and select **Add Shift Register** from the shortcut menu to create a shift register.
5. Right-click the left terminal of the shift registers and select **Add Element** from the shortcut menu to add an element to the shift register.
6. Modify the block diagram as follows.

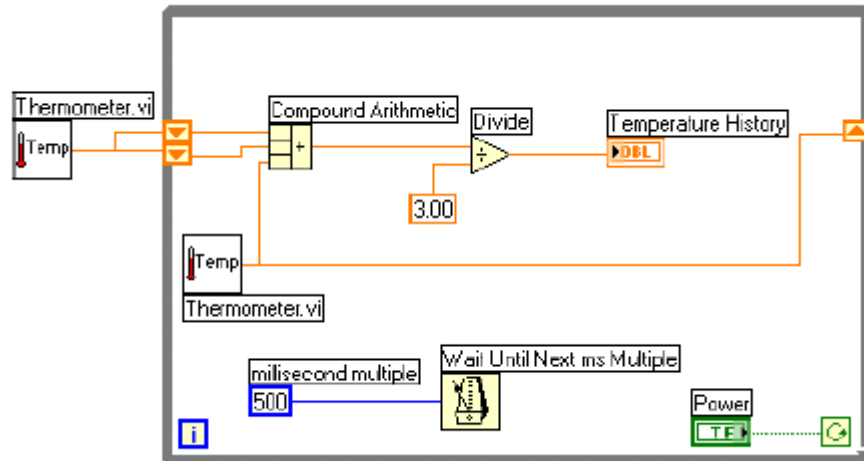

- a. Press the <Ctrl> key while you click the Thermometer VI and drag it outside the While Loop to create a copy of the subVI. **(MacOS)** Press the <Option> key. **(Sun)** Press the <Meta> key. **(Linux)** Press the <Alt> key.

The Thermometer VI returns one temperature measurement from the temperature sensor and initializes the left shift registers before the loop starts.

- b. Place the Compound Arithmetic function located on the **Functions»Numeric** palette. This function returns the sum of the current temperature and the two previous temperature readings. Use the Positioning tool to resize the function to have three left terminals, shown at left.

- c. Place the Divide function located on the **Functions»Numeric** palette. This function returns the average of the last three temperature readings.

- d. Right-click the y terminal of the Divide function, select **Create»Constant**, type 3, and press the <Enter> key.

- e. Use the Labeling tool to double-click the numeric constant wired to the Wait until Next ms Multiple function, type 500, and press the <Enter> key.

7. Save the VI because you will use this VI later in the course.

8. Run the VI.

During each iteration of the While Loop, the Thermometer VI takes one temperature measurement. The VI adds this value to the last two measurements stored in the left terminals of the shift register. The VI divides the result by three to find the average of the three measurements, the current measurement plus the previous two. The VI displays the

average on the waveform chart. Notice that the VI initializes the shift register with a temperature measurement.

9. Place the Bundle function located on the **Functions»Cluster** palette to display both the average and the current temperature measurement on the same waveform chart. This function bundles the average and current temperature for plotting on the waveform chart.

10. Save and run the VI. The VI displays two plots on the waveform chart. The plots are overlaid. That is, they share the same vertical scale.

Week 2

Exercise 2

Filtered and unfiltered signal

Note: Unlike week 1 step by step procedure is not given. Students are encouraged to draw the block diagram on their own using a few tips mentioned below. In case of any doubts, call your instructor for help.

Aim

- To understand the use of filtering a signal
- Learn to save data
- To understand the use of formula node
- To measure the peak to peak amplitude at various intervals
- To understand the operation of a warning signal.

Procedure

Front Panel

1. The front panel appears as follows.

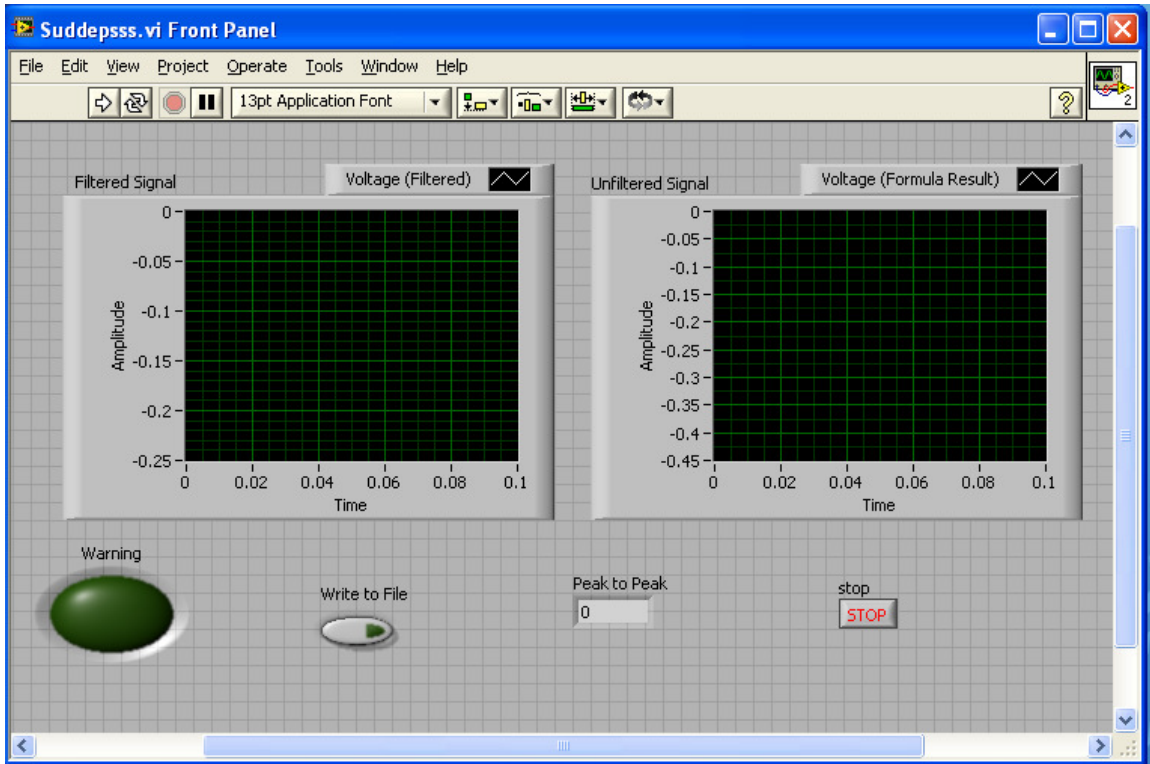

2. To display the filtered and the unfiltered signal we require having two waveform graphs.
3. To display the peak to peak amplitude, it is necessary to have one numeric indicator.
4. To display the warning. A round Led is being used. **Right click on the front panel>Boolean>Round Led**. Resize the Led using positioning tool.
5. In order to save data only at regular intervals of time, it is necessary to introduce a button, so that whenever the button is pressed the data gets saved. **Right click on the front panel>Boolean>Push Button**. Rename the button as **Write to file**. **Right click on the button>Mechanical action>select latch when pressed action**.

Block Diagram

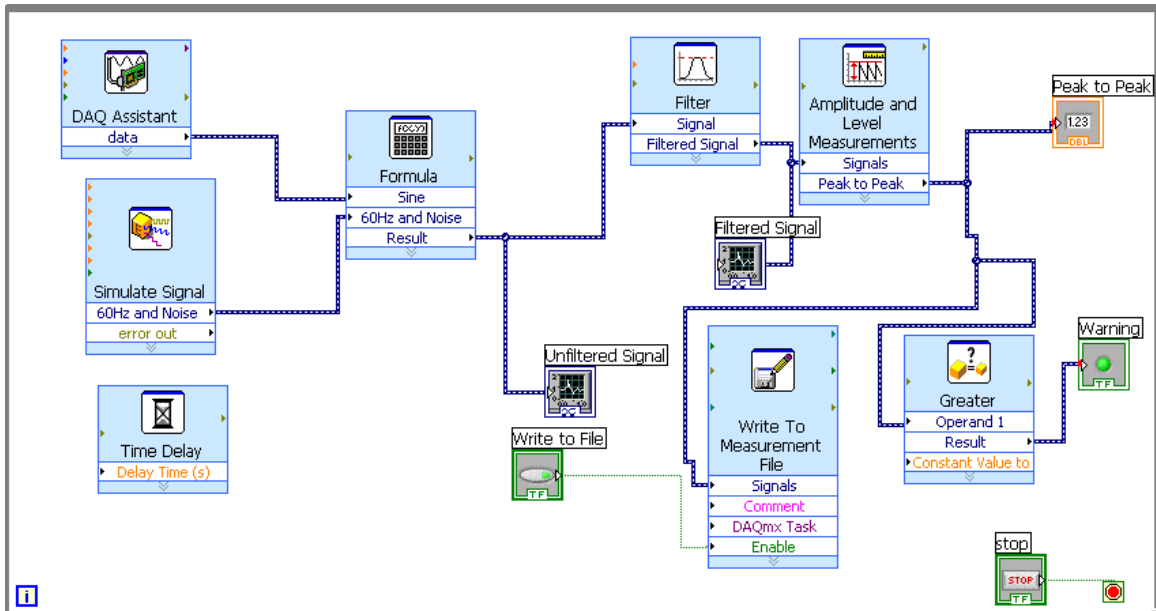

5. The first step in building the block diagram is to stimulate a signal. **Right click on the block diagram>Express>Input>Simulate signal.** In the property box accept all defaults.
6. Since the above stimulated signal has no noise, it is essential to introduce noise to understand the concept of filtering. **Right click on the block diagram> Express>Input>Stimulate Signal.** In the property box check mark on “Add Noise” and select **uniform white noise** from the pull down menu. Ensure that the **Noise amplitude is 0.1** and **seed number is -1**. Check mark signal name and enter **60Hz and Noise**.
7. To merge the two signals we use the **formula node**. **Right click on the block diagram>Express>Arith and compare>Formula.** In the property box under label in place of **X1** enter **Sine** and in place of **X2** enter **60 HZ and Noise**. Add the two elements. Click **X1+X2**
8. Next step is to filter the signal. **Right click on the block diagram>Express>Signal Analysis>Filter.** In the property box under filtering type select **High pass** and accept all other defaults.
9. The next step is to measure the peak to peak amplitude. **Right click on the block diagram>Express>Signal Analysis>Amp and level.** In the property box click **Peak to Peak**.
10. The next step is to introduce the warning signal when the peak to peak amplitude crosses a cut off value. **Right click on the Block diagram>Comparison>comparison.** Under compare condition check mark **Greater** and under comparison inputs check mark **value** and enter **2**.
11. The next step is to save the data to a file. **Right click on the block diagram>Express>output>Write measurement file.** In the property box

under action check **Ask user to choose file** and **ask each iteration**. Accept all other defaults.

12 In order to repeat the process introduce a **While loop**.

13 You can also introduce a **Time delay** function. With a delay of **0.2** seconds.

Wiring

- **Wire the two stimulated signals to the formula node.**
- **Results from the formula node to Signal. It's also necessary to Wire the results from the formula node to Unfiltered Signal Graph**
- **Filtered signal to Amplitude and Level measurements and also to filtered signal graph.**
- **Output of peak to peak amplitude to the Peak to Peak Indicator, also to Comparator, also to write measurement file.**
- **Connect the write to file button to write measurement file.**
- **Connect the result of the comparator to the warning LED.**

Save the program

Run the program and verify if the signal is filtered.

Test (Compulsory)

After you have completed the exercise, replace the simulate signal with the DAQ board Signal and analyze the results.

End of Exercise

Week 2

Exercise 2

Digital I/O

Aim

- To understand the concept of arrays
- To control the digital I/O lines on the DAQ device
- To ensure that the LED's on the front panel and the DAQ device match.

Procedure

Front panel

The front panel appears as follows:

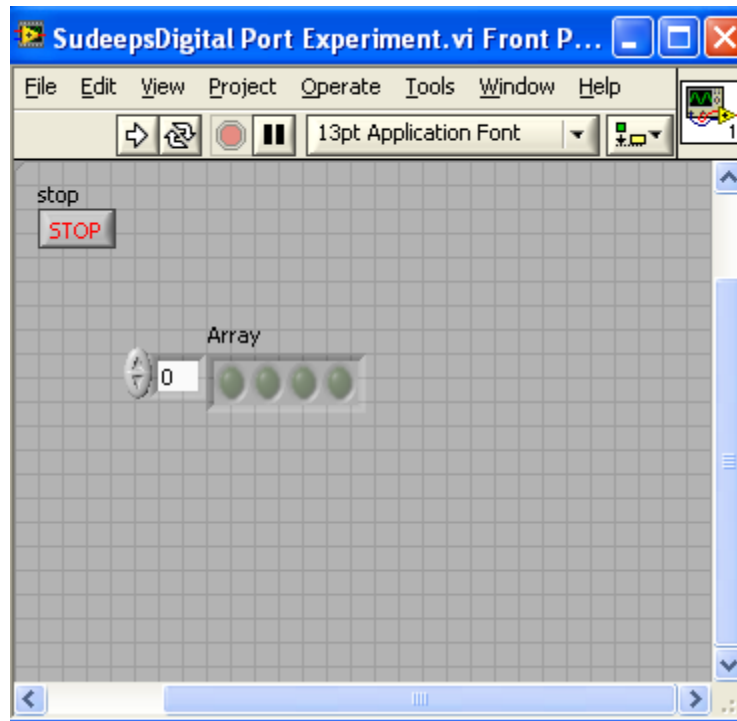

1. In order to incorporate LED's within an array the following procedure must be followed. **Right click on the front panel>Array>Array.**
2. **Right click on the front panel>Boolean>Round LED.** Place the LED inside the array. Using the positioning tool stretch the array in horizontal direction (towards right) until four LED's appear on the front panel. Number 4 is chosen because the number of LED's on the DAQ board is 4.

Block diagram

Note: Components needed to build this program has been summarized below. Students are encouraged to build the block diagram on their own. Call your instructor in case of any queries.

3. **Right click on the block diagram>Array>Array subset.** Since there are 4 LED's the length of the subset needs to be 4. Create a **constant** and assign a value **4**.
4. In order to reverse the order of the elements. **Right click on the block diagram>Array>Reverse 1D array.**
5. Next step is to convert the Boolean array to Numbers. **Right click on the block diagram>Boolean>Array to Number.**
6. The next step is to build the array. **Right click on the Block diagram>Array>Build array.**

7. To activate the LED's on the DAQ board, the DAQ assistant needs to be incorporated. (Configure the DAQ assistant on the block diagram on your own)
8. A while loop may be needed for smooth operation.
9. Save the VI
- 10 Run the VI.

Test (Compulsory)

Do you think a logic gate is required for better operation?

Try incorporating a logic gate? (Ask your instructor whether the logic gate selected by you is right or wrong?)

What would be the connections to this logic gate?

End of the Exercise