

Electronic Circuits and Components

An “Electronic Circuit “ is a **combination of electronic components and conductive wires** interconnected in a way as to achieve an outcome:

- Achieve a current /voltage of a certain value (signal)
- Amplify a signal
- Transfer data

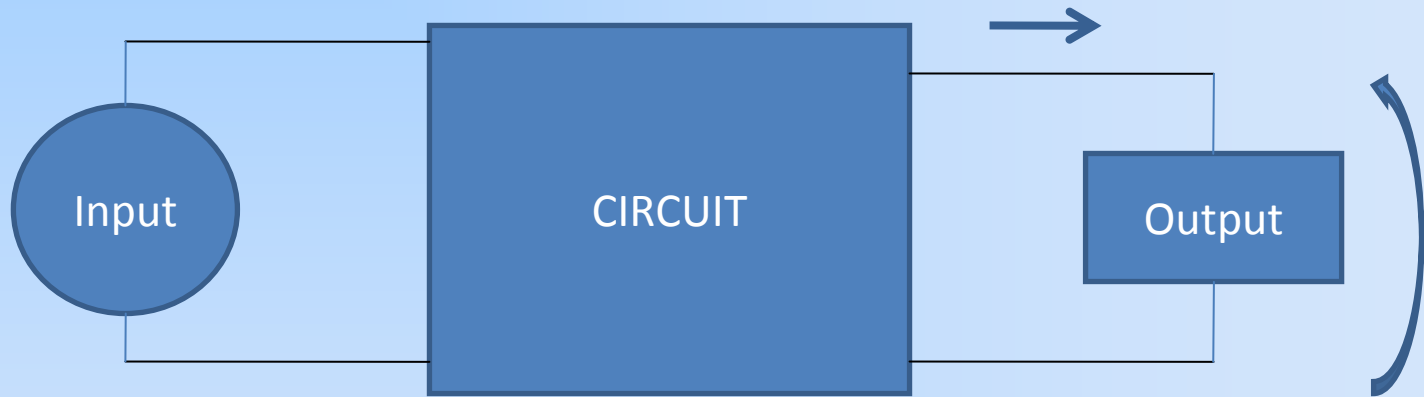

The purpose of an electronic component is to allow the designer to **control the flow of current** as to achieve a specified result/output.
(Resistors, Capacitors, Inductors, Diodes, Transistors)

Electronic Components

Active Components (have directionality)

Semiconductor devices-transistors

Passive Components (Have no directionality)

Resistors, capacitors, inductors, diodes
(diodes and polarized capacitors must be
installed in a specified way)

A. Resistors:



Resistors are passive elements that **oppose/restrict the flow of current**.

A voltage is developed across its terminal, proportional to the current through the resistor.

$$V = IR$$

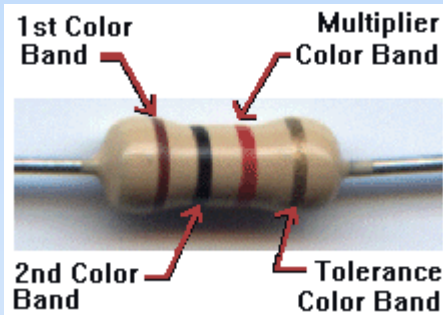

Units: Ohms (Ω)

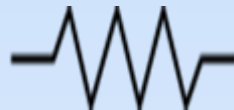

B. Capacitors



- behave like a tiny rechargeable battery.
(store energy and release it later.)
- are made of two parallel conductors separated by a dielectric.
- are used for **filtering, tuning, separating signals , etc.**
- The ability of a capacitor to store charge is called **“Capacitance”**
- **$C = Q/V$** (*amount of charge stored/applied voltage*)
- The unit of capacitance is the **Farad**.
Commonly used capacitances are much smaller than 1 Farad, micro-Farads (10^{-6} Farad, **μF**),
nano-Farads (10^{-9} Farad, **nF**),
pico-Farads (10^{-12} Farad, **pF**).

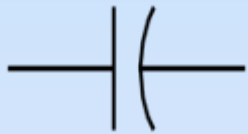

Transistors

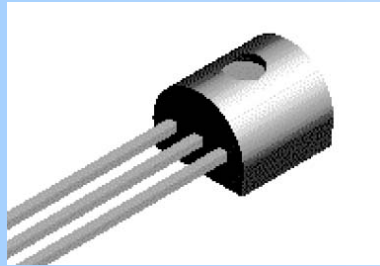

Symbol for the NPN Transistor

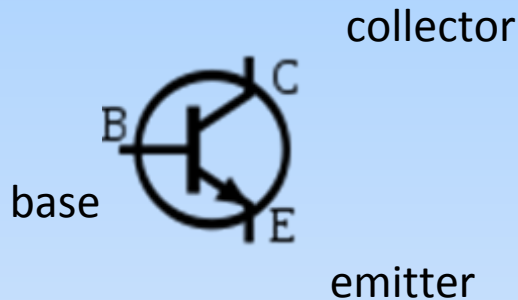

Transistors are commonly used for **signal amplification, switching, voltage regulation, etc.**

Symbol for the PNP Transistor





Diodes are semiconductor devices that **allow current in only one direction**



Fuses are devices that **protect the circuit from overload.**

Are made of a wire that melts when the current through it exceeds a specified value

Q5. Which of the following components used in a circuit stores energy?

- a. Resistors
- b. Inductors
- c. Capacitors
- d. Diodes
- e. Transistors

Q6. Which of the following components used in a circuit allows the current to flow one way

- a. Resistors
- b. Inductors
- c. Capacitors
- d. Diodes
- e. Fuses



LEDs- Light Emitting Diodes:

- A special kind of diode: They allow current to flow in one direction.
- The LED will light up when the proper amount of current passes through.

1-3

4

5

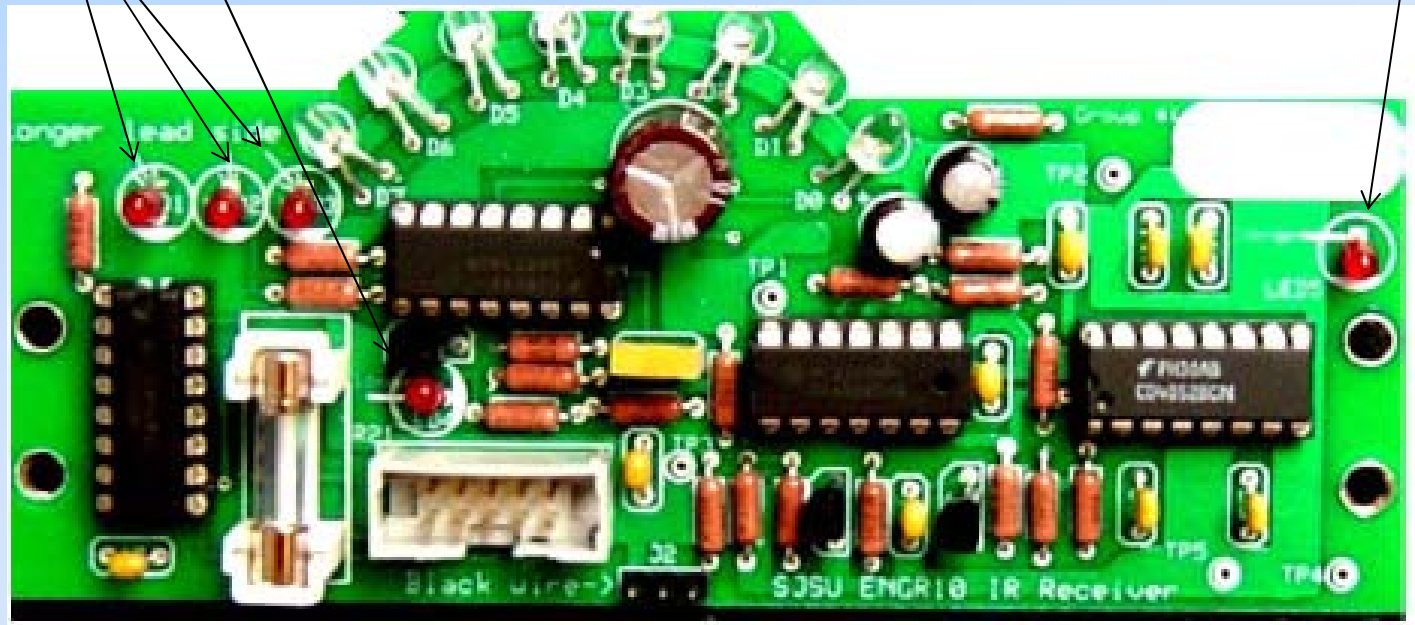

Infrared Detectors

- The appearance of these infrared photo detectors and the internal structure is similar to that of an LED.
- The infrared photo detector has a focal direction, and the detection angle is about 15° . ($8 \times 15 = 120^\circ$)
- This small detection angle allows the controller to **tell the direction where the infrared light comes from.**

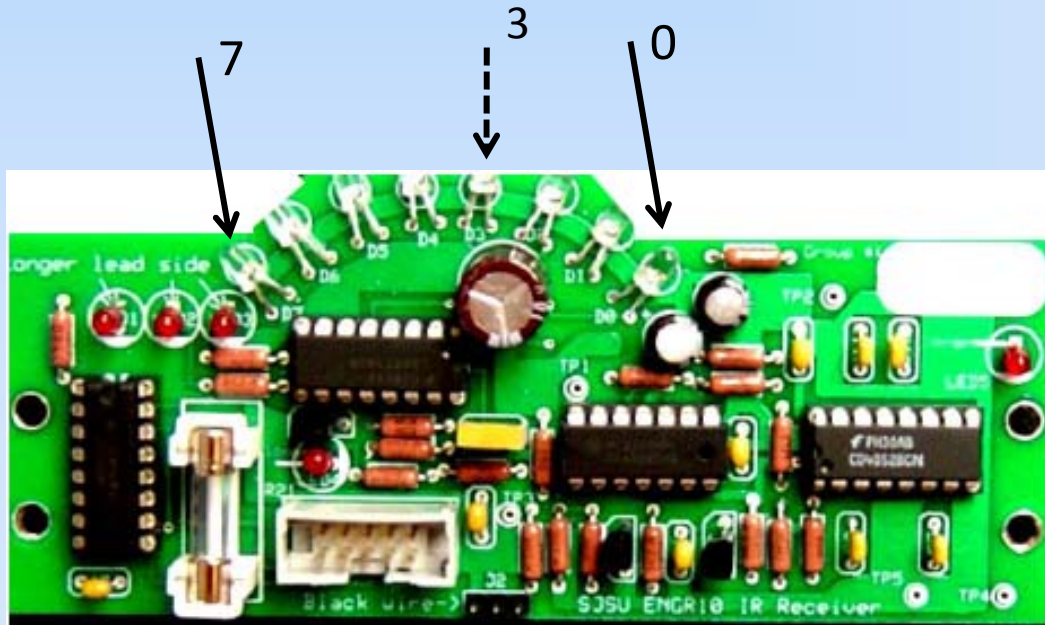

Integrated Circuits

A small scale electronic CKT on a substrate of semiconductor material

Orientation

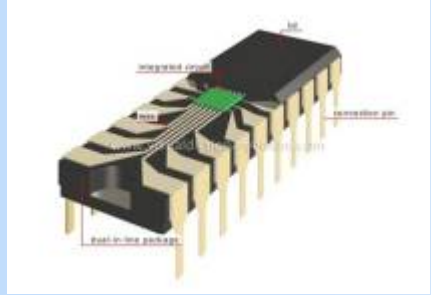

Selector

Amplifier

Counter

Tuning CKT

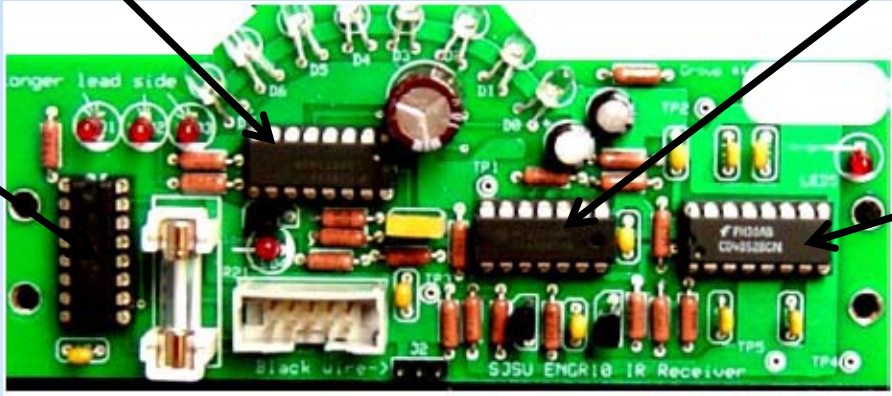

Robotic Component Functional Summary*

B. Motors

- Motors are devices that can transform electrical energy into mechanical energy.
- Control the movement/speed of the robot.
- Direction: **CW** or **CCW**.
- SWR Command:
 - **SetPWM[Port #, Direction & Speed#]**



- Range: Direction & Speed:
 - **000** **CCW-High**
 - **127** **STOP**
 - **255** **CW - High**



Robotic Component Functional Summary (cont.)



C. Servos

Servo motors are a type of motor that can be **directed to turn to a specific direction**, rather than just spin forward or backward.

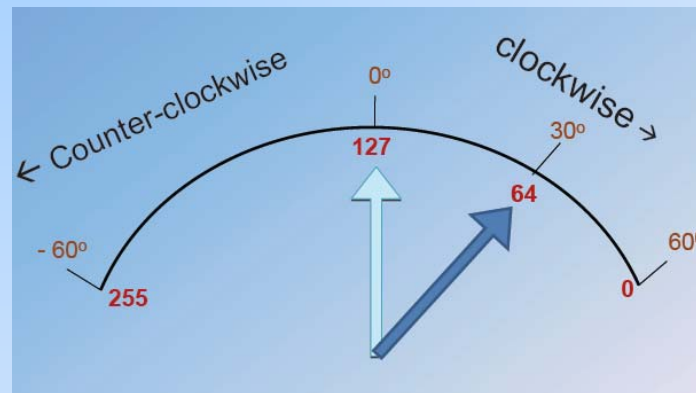

SWR Command: **SetPWM [Port#, Direction Value]**

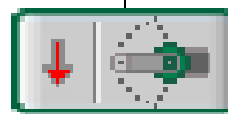

```
SetPWM ( 1 , 255 );
```



C. The Bumper

- The bumper switch is a digital sensor.
- It tells the robot whether the bumper on the front of the sensor is being pushed **in or not**.

SWR Command: **bumperL = GetDigitalInput[Port#]**

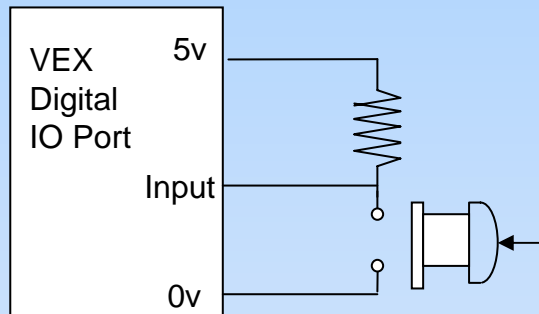

Input =1 (or 5V) when the bumper is not pushed.

Input =0 (or 0V) when the bumper is pushed.

D. The limit switch (similar to Bumper SW)

- The limit switch is a digital sensor.
- It can tell the robot whether the sensor's metal arm is being pushed down or not.

SWR Command: **GetDigitalInput[Port#]**

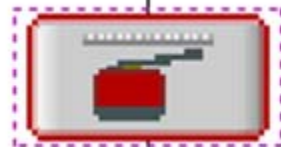

```
LimitSwitch = GetDigitalInput [ 7 ] ;
```

- When the limit switch is not being pushed in, the sensor maintains a digital HIGH signal on its sensor port. (1 or 5v.)
- When an external force (like a collision or being pressed up against a wall) pushes the switch in, it changes its signal to a digital LOW until the limit switch is released. (0 or 0v.)

Q7. What is the state of the bumper input in Fig 1.?

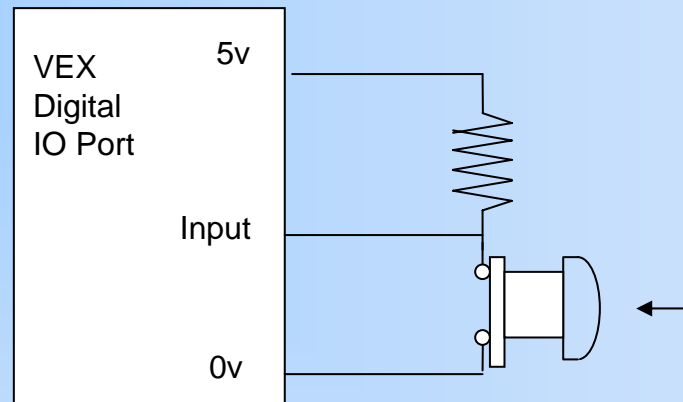

Fig. 1.

- a. Input =1 (or 5V).
- b. Input =0 (or 0V)

Ultrasonic range finder



An ultrasonic range finder sensor enables a robot to detect obstacles in its path by utilizing the propagation of high-frequency sound waves.

The sensor emits a sound wave, which bounces off a reflective surface and returns to the sensor. Then, using the amount of time it takes for the wave to return to the sensor, the distance to the object can be computed.

Robotic Component Functional Summary (cont.)



The light sensor

The light sensor uses a photocell that allows your robot to detect and react to light.

Analog input of light levels:
Find dark or bright areas.

It uses a photoconductive photocells which are photo resistors, meaning that their resistance value changes based on the amount of incident light.