

Welcome to E10

A Freshman Engineering Experience

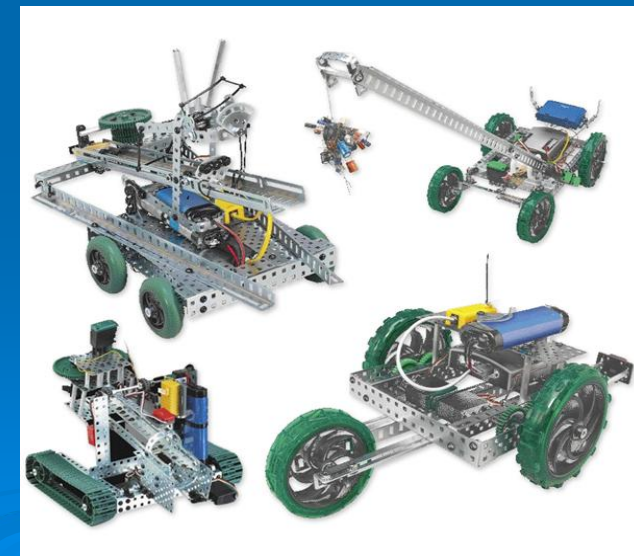
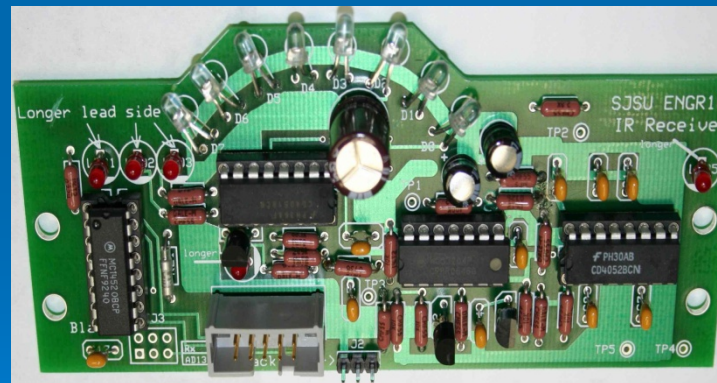
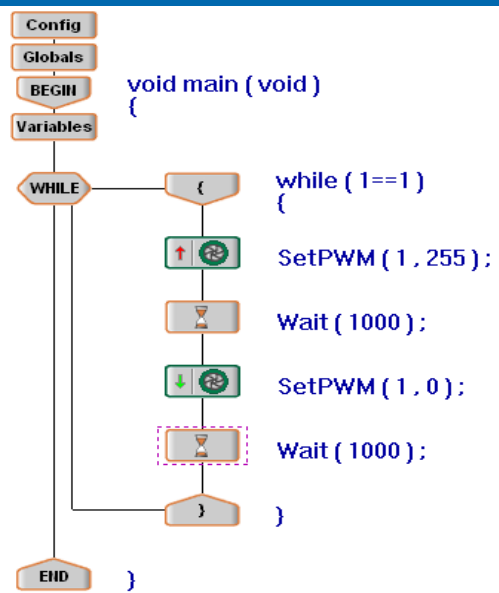
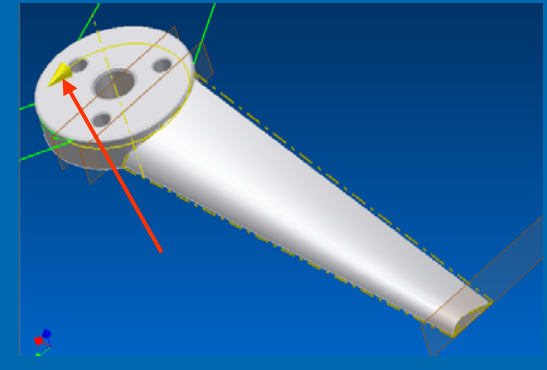
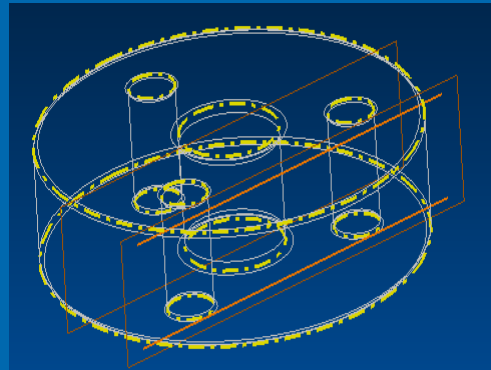

Prof. John Athanasiou
Fall 09

Thank you for turning it off





Do use it for:

Note taking



Anything else



Before we start....

Let me tell you a story

The "Freshman" Challenge

- A college freshman, attending a recent football game, tried to explain to a senior citizen sitting next to him why it was impossible for the older generation to understand his generation.

"You grew up in a different world, an almost primitive one " the student said,
...the young people of today have grown up with HDTV, cell phones, space travel and spaceships visiting Mars. We have nuclear energy, electric and hydrogen cars, computers with light-speed processing...and", pausing to take another drink of soda.

The Senior citizen took advantage of the break in the student's explanation and said,

"You're right, son. We didn't have those things when we were young, so we invented them, designed them, tested them, mass-produced them

Now, the question is.....

The “Freshman” Challenge (cont.)

*what are you going to do
for the next generation?”*

Today's Discussion

- What is Engineering?
- What do Engineers do ?

First Thing First

How /Why did you selected engineering as your major?

1. "Because of the engineering classes at my high school"
2. "I did well in math or science."
3. "My mother told me "be an engineer or die"."
4. "My father and brother are engineers."
5. "I've always been curious as to how things work."
6. "I like to fix things"
7. "I heard that the salaries are higher that for other majors"

(" " students answers)

Guess what?

Most engineers discover engineering in Colleges and Universities.

Family and friends have a lot of influence on our decisions

At the end, however, it is **your decision**

Show me the \$\$\$\$

- Earnings for engineers vary significantly by specialty, industry, experience and education.
- As a group, engineers earn some of the highest average starting salaries among those holding bachelor's degrees. *
- New college graduates with degrees in the engineering and computer science fields boast the highest average starting salaries. **
- **U.S. Department of Labor
Bureau of Labor Statistics
- * National Association of Colleges and Employers (NACE).

Average Starting Salary- Summer 2008 (NAC&E*)

Chem. Engr.....	\$63,165	(petroleum Ind.)
Civil Engr.....	\$51,632	
Elect. Engr.....	\$56,009	
Mech. Engr.....	\$57,009	
Accounting.....	\$48,085	
Finance.....	\$48,547	
English.....	\$34,327	
Psychology.....	\$33,564	
Sociology.....	\$34,796	

➤ * National Association of Colleges and Employers

Mechanical Engineer (and all engineering fields).

*With every passing year, more skilled-labor jobs are replaced by complex automation or robotics systems. For example, some hospitals have turned to "robotic pharmacies" to help dispense medication. It's the engineers who help build these automated systems, says Jim Turnquist, director of career services at Michigan Technological University in Houghton, Mich. "In the U.S. we only graduate 70,000 engineers per year, but we're going to need 100,000 per year. The demand is going to go way up." **Average Yearly Salary - \$71,490***

Software Designer/Developer.

*Companies from all sectors of the economy are looking for software engineers and programmers, says Turnquist. This is because society in general is becoming more tech-dependent -- just think of how rapidly cell phones change with each passing year -- requiring software developers that can stay abreast of all the changes. **Average Yearly Salary - \$72,070***

Source: Yahoo.com 01/12/09. All salary data is from PayScale.com. The salaries listed are median, annual salaries for full-time workers with 5-8 years of experience and include any bonuses,

How do I learn more about engineering?

1. E10 class
 - a. Hands-on projects
 - b. Team work environment.
 - c. Professors from various engr. disciplines
2. Your classmates*
3. Student chapters of a professional society.
4. Your professors
5. Other practicing engineers.
6. Visiting engineering companies.
7. Apply for student internships during summer

Engineering is....

- A Profession
- Design
- Development
- Test
- Assembly/Production
- Engineering is also
 - Team Work
 - Communication
 - Ethics

Life Long Learning

All professionals are expected to keep up with the changes/advances of their profession.

Engineers need to keep up with the advances of science and technology:

- New Tools, Measurement Techniques,
- Manufacturing Methods
- New Materials, Products,
- New Local, Federal and Environmental laws

Engineers Solve “Problems”

Some examples of engineering problems:

- Cars:
1. Safety-crash test
 2. Pollution
 3. Gas consumption
 4. Metal and tire recycling.

- Computers:
1. Battery life and safety (laptops)
 2. Recycling of special components
 3. Size, weight, cost, capacity, speed.

Non invasive medical diagnostic equipment.

Traffic congestion.

Can you think of other “engineering” problems



The Engineer's Balancing Act

Example:

The design of a laptop must meet the following:

- Light weight --- Large screen
- Small in size --- Comfortable key board.
- Reduced price --- Many functions (DVD, Phone, Internet, Graphics, etc.)

The engineer must find an “optimum” design to satisfy the given constraints.

[*Constraints and optimization*]

The “Magic” We Call Engineering

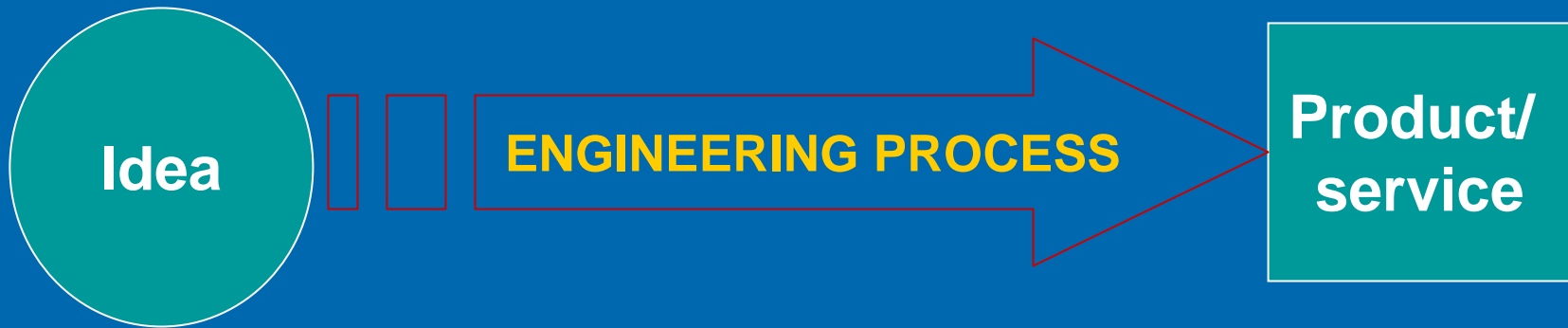

The Engineering Design Process

- Engineering design is a **process.**
- A process is a series of inter-dependended operations each one with a set of input and output requirements.

Basic process step:



Question

Does team work play any role in the engineering process?

The Basic Elements of a Process

- **Manpower** (people with skills, team work)
- **Material** (raw material, components)
- **Machinery** (tools, etc.)
- **Methods** (procedures for test, assembly etc.)
- **Money** (investment to start with)

The Story of Engineering Knowledge

- Once upon a time....there was a gifted engineer who had retired after 35 years. Several years later, his company contacted him regarding an impossible problem they were having with their multi-million dollar system.
- The engineer reluctantly took the challenge and after he spend several hours studying the system hardware, he marked a small “x” with a marker, on a particular component and told management to replace it.
- The company received a bill for \$50,000.
- Management immediately asked for an itemized accounting for the charges.

The Engineers Itemized Accounting

- One black marker \$1.00
- Knowing where to place it....\$49,999

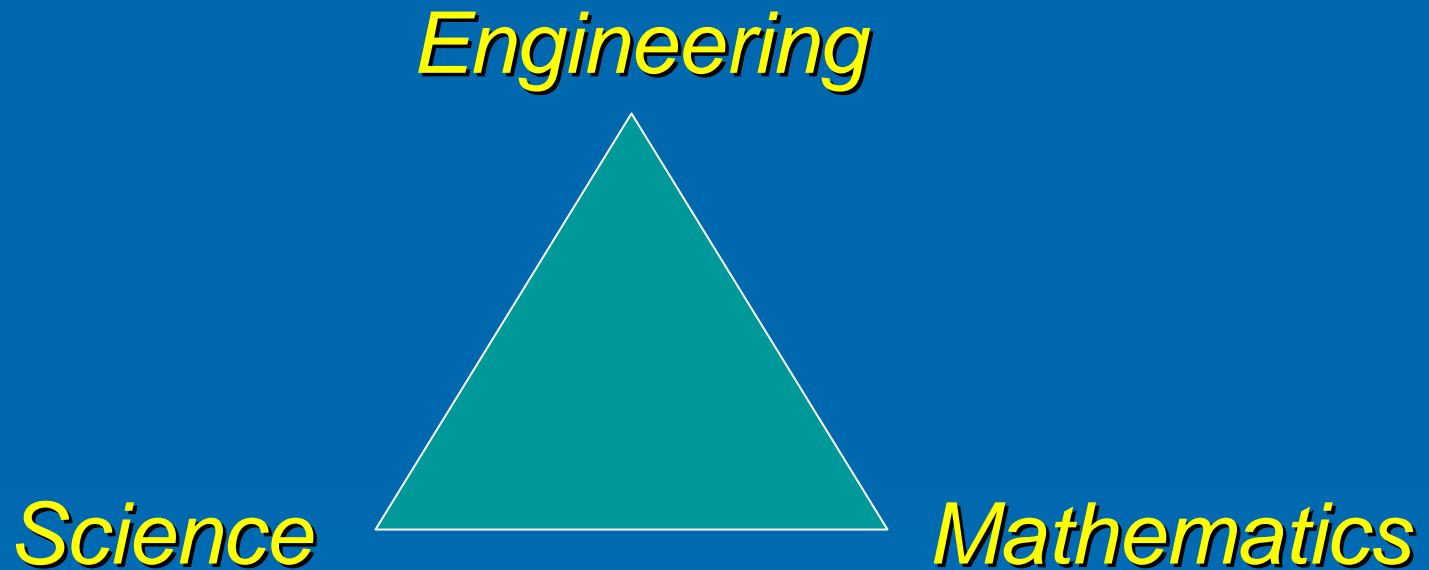

Science/Math vs. Engineering

- Science: Study the laws of nature
Generates new knowledge.
- Engineering: -Converts science into technology
-technology into useful products.

It requires creativity, judgment,
imagination, experience,
- What About Math.: One of the best
engineering tools

What science tell us about magnets?

➤ Magnetic poles

➤ Magnetic field

➤ Direction

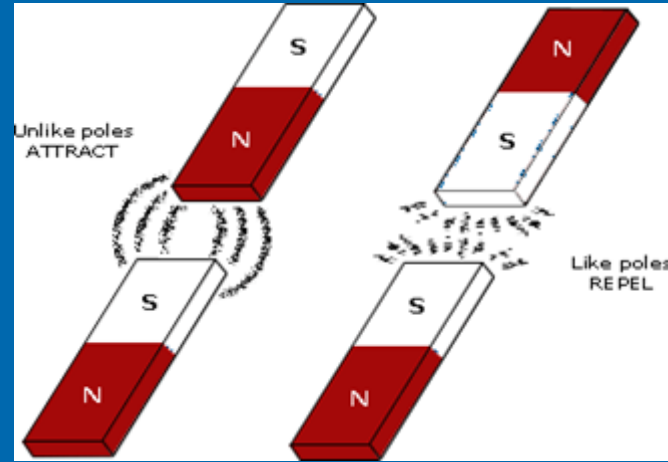

Ref 1

Ref 2

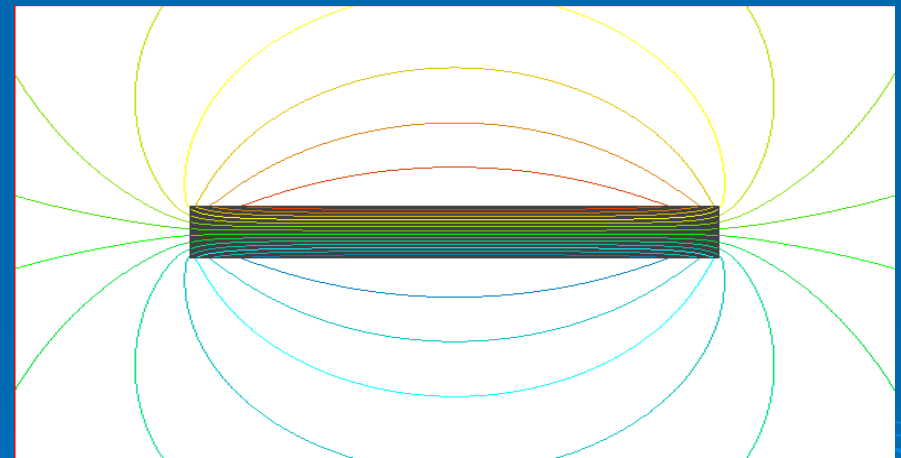

Science

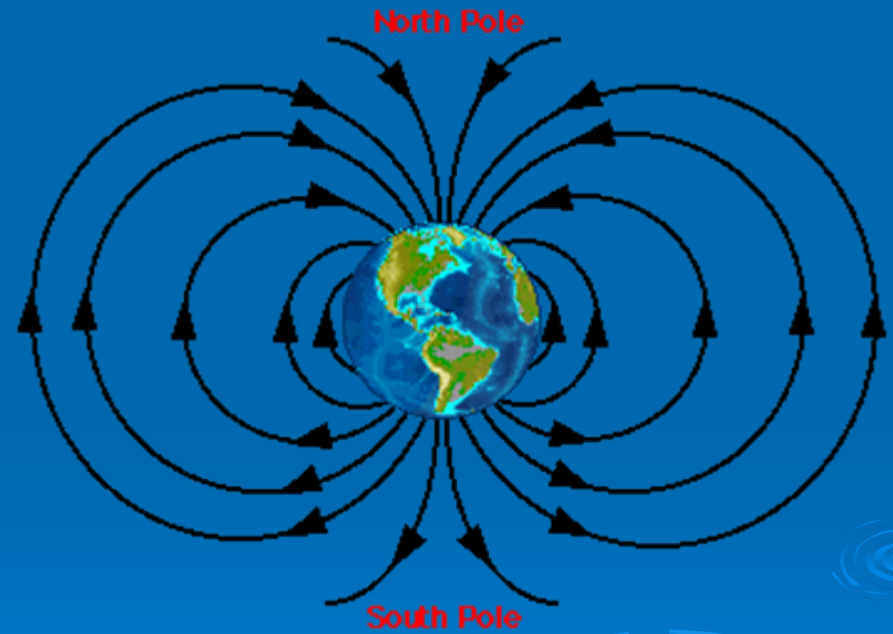

Ref 3

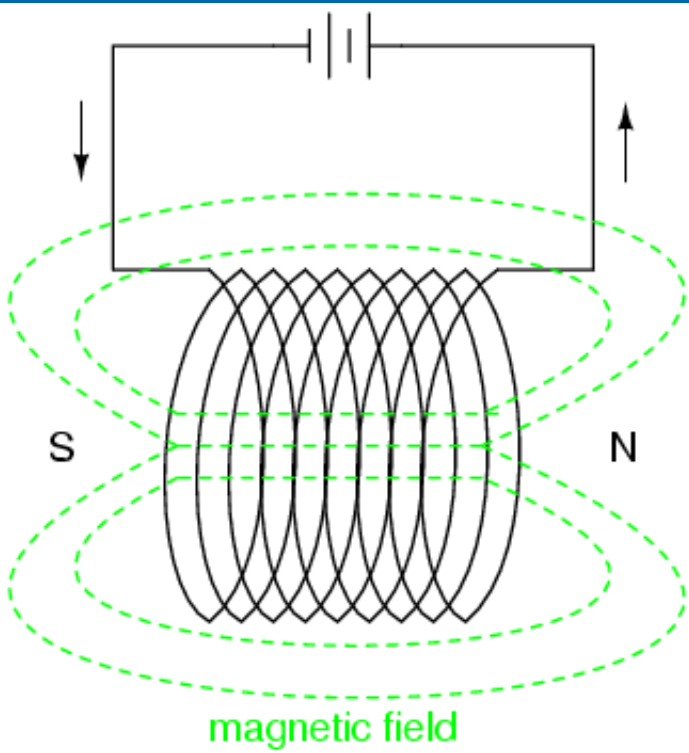

➤ Current through a coil:
➔ magnetic field

➤ Coil into a magnetic field:
➔ current through the coil

What do these products have in common?

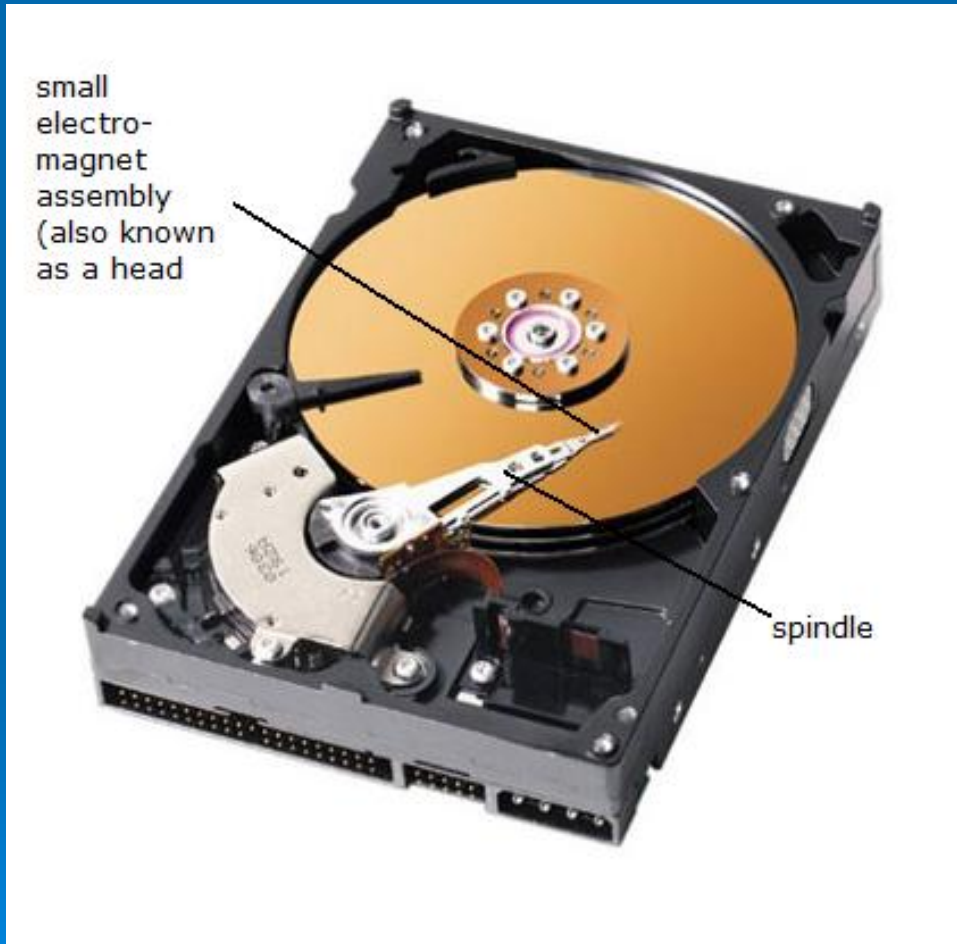

Ref A

Ref E

Creativity, Imagination & the Start of a Multibillion \$\$\$ industry



Ref. B



D

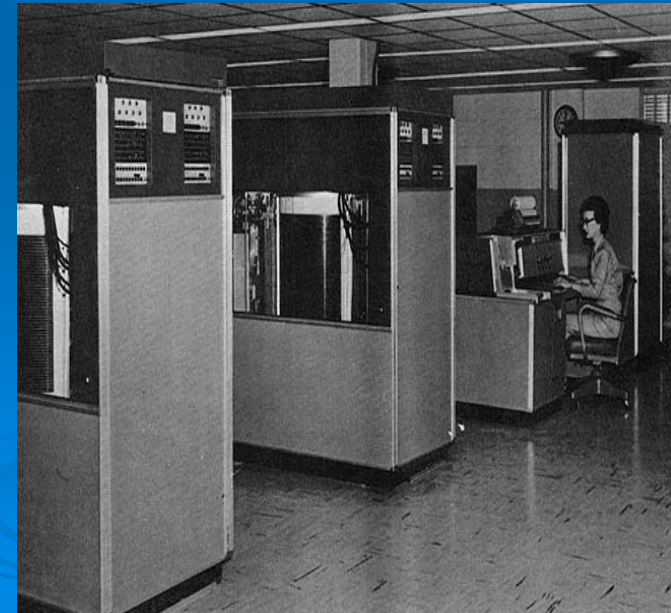

Read/Write head on the surface of a magnetic disk

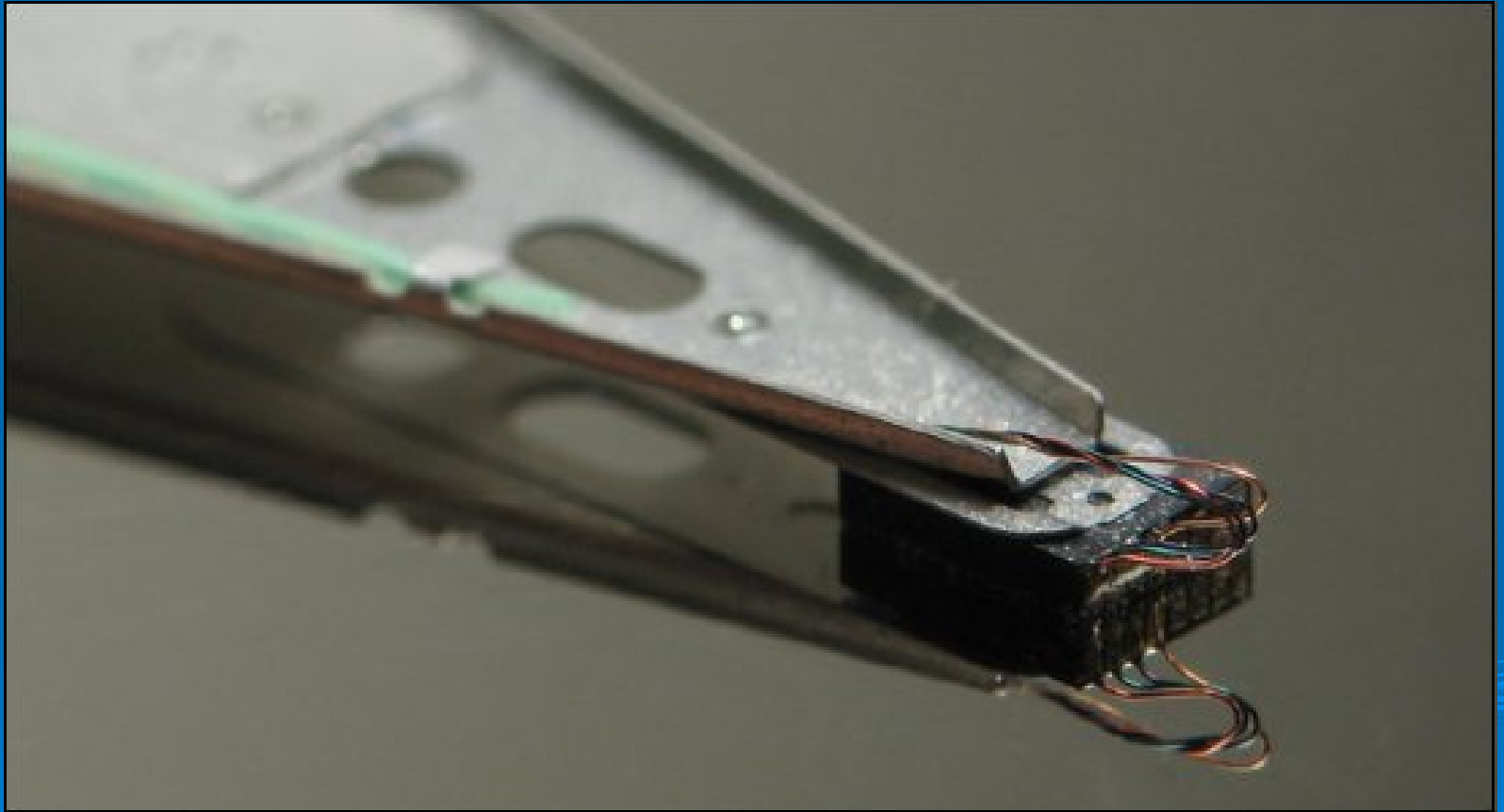

Ref. C

Read-Write Current

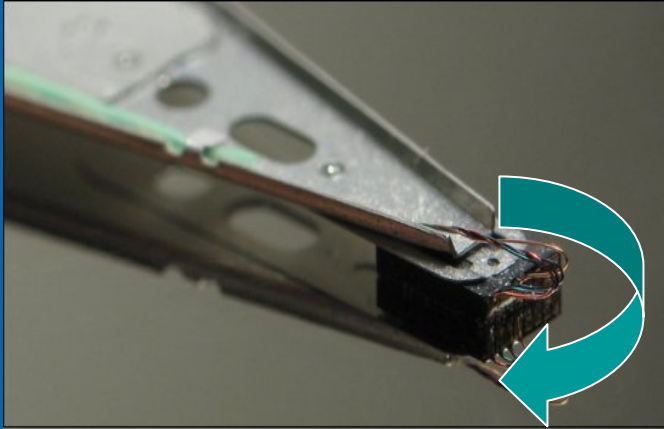

- Current through the coin
- Magnetic field
- Disk surface magnetized

- Magnetized disk surface
- Coil into the disk magnetic field
- Current generated through the coil

From Science to Engineering via Imagination

- **“File Save”** **“Write operation”**
(The current in the “coil” of the “write” head element magnetizes portions of the disk surface)
- **“File Open”** **“Read Operation”**
(the coil of the “read” head element passes over the magnetized surface and “reads” the signal)

From Science to Engineering

The Theory/observation

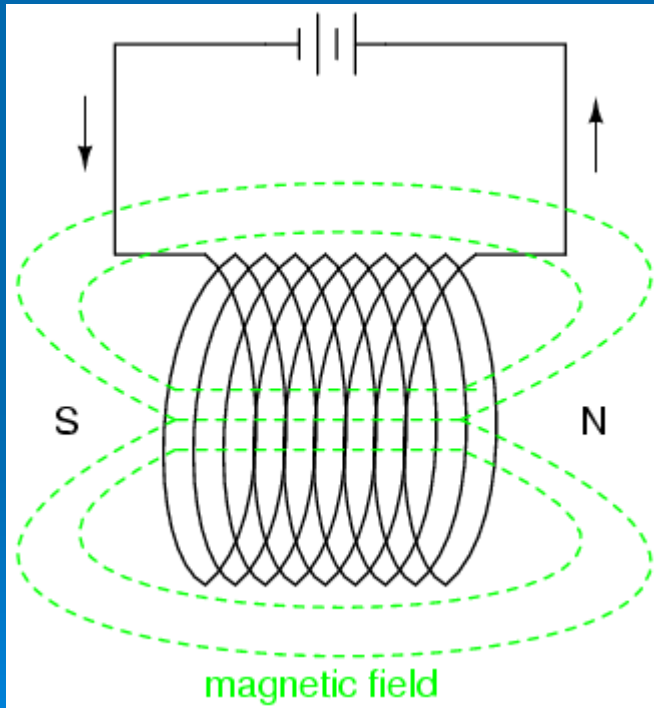

Engineering



The End Product

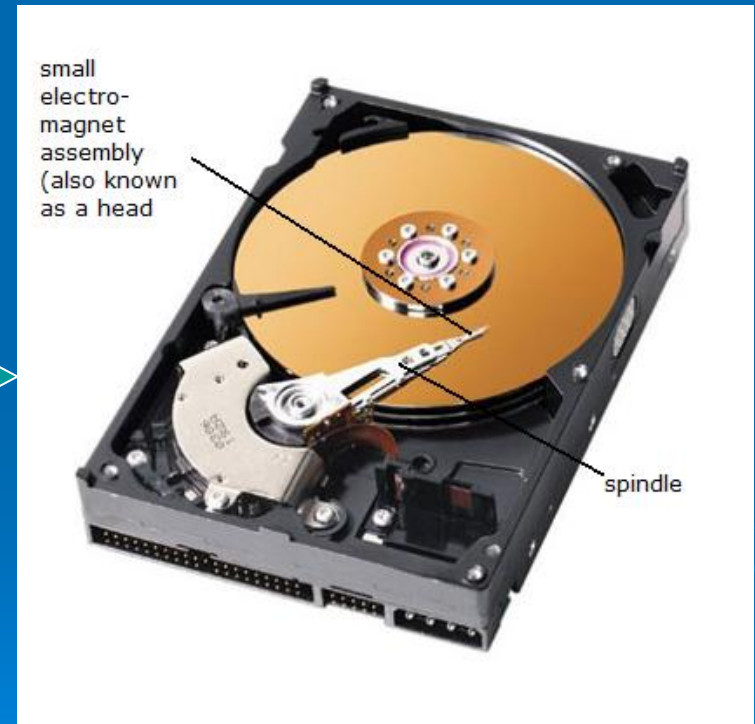

So, What Engineers Do????

1. **Design** products.
2. **Design** machinery to **build** those products.
3. **Design** plants in which those products are made.
4. **Design** the systems that ensure the quality and efficiency of the manufacturing process.
5. **Design, plan** and **supervise** the construction of buildings, highways, transit systems.
6. **Develop** and **implement** ways to extract, process and use raw materials such as petroleum and natural gas.
7. Harness the power of the **sun**, and **wind** to satisfy the nations power needs.

“In a Nut Shell”

- “Engineers *apply* the theories and principles of science and **mathematics** to **research** and **develop** **economical solutions** to technical problems.”
- U.S. Bureau of Labor Statistics

The Engineering Design Process. (text)

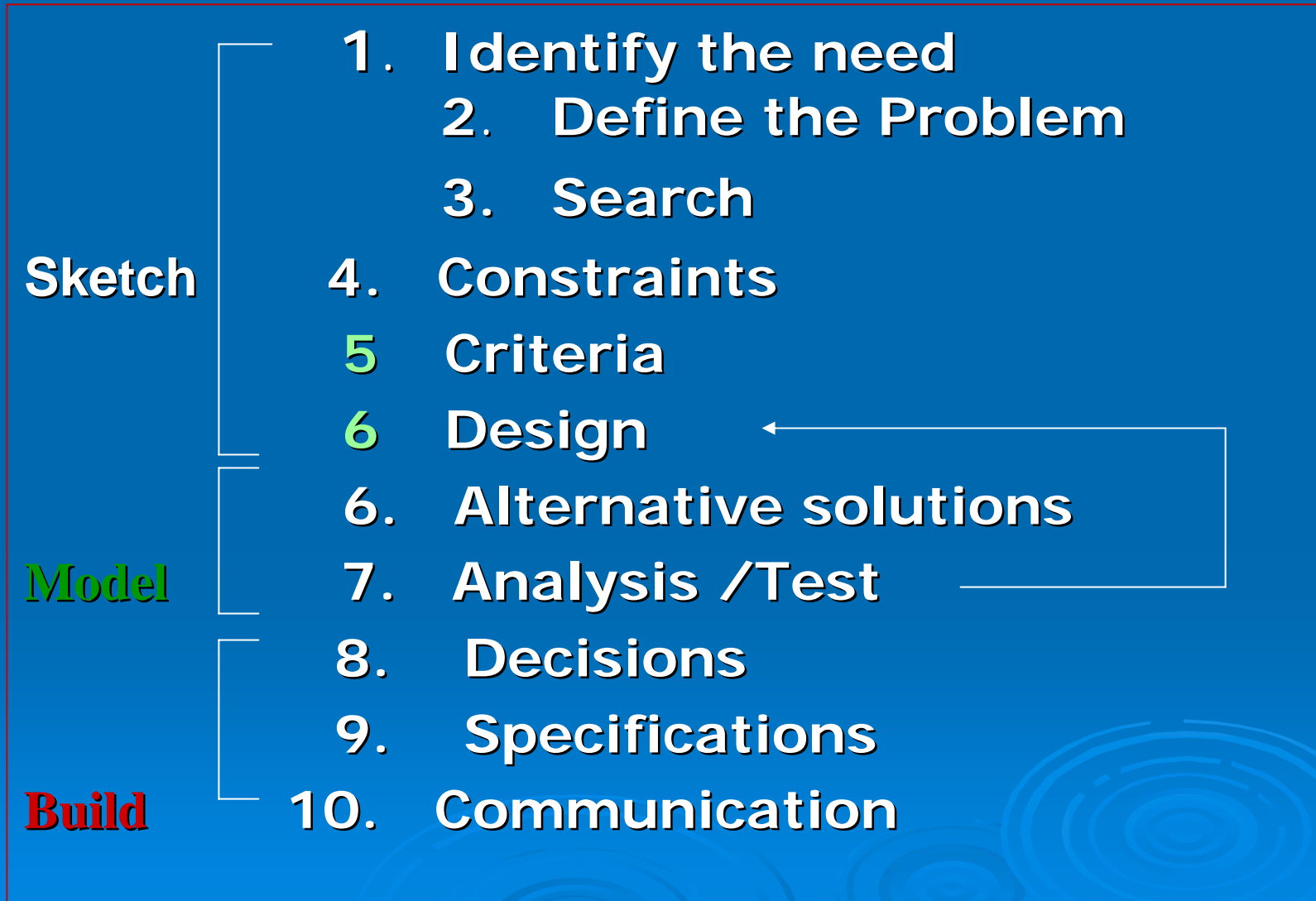

- There will be a more discussion on “engineering design” later on in the semester.

What Did We Discuss Today?

- Engineering transforms ideas into useful products.
- Your classmates are a good source of information.
- Salaries for engr. majors are higher than other majors.
- Science studies the law of nature.
- Engineering converts science into technology / products through creativity, imagination, judgment, experience.
- Engineering transforms ideas into useful products.
- Engineers design products within a set of constraints
- Engineering is a process that includes people, materials, machinery, methods, money.
- Engineers are committed to Life Long Learning.

Thank you for your participation



Ref. F

Ref.

- Pictures by “Google”
- Ref. 1 <http://www.howmagnetwork.com/attractrepel2.gif>
- Ref 2: <http://www.coolmagnetman.com/maggallery.htm>
- Ref 3: <http://www.unc.edu/depts/oceanweb/turtles/geomag.gif>
- Ref 5=http://www.sciencebuddies.org/mentoring/project_ideas/Elec_img079.png
- A =<http://chauncy-ict.pbwiki.com/f/adding-a-hard-drive-1.jpg>
- B=http://images.pcworld.com/news/graphics/127104-MB_RAMAC_compare.jpg
- C=http://www.pctechguide.com/31HardDisk_Construction.htm
- D=<http://www.zdnet.fr/zdnet/i/edit/39380831/b-disquedur.JPG>
- E=http://sendmedeadflowers.com/uploaded_images/jukebox-722780.jpg
- F=<http://www.schwimmerlegal.com/smiley.jpg>