

Wind Turbine Power Measurement Procedure

In this lab, we determine the maximum electrical power that your wind turbine can generate. This involves the use of two key components: a power meter and a load box. We first introduce these two components.

Power Meter

A **power meter** is a circuit that simultaneously measures the voltage across and the current through a pair of wires. The circuit also multiplies the values of voltage and current to produce the value of the power flowing through this pair of wires. Figure 1 shows the structure of the power meter.

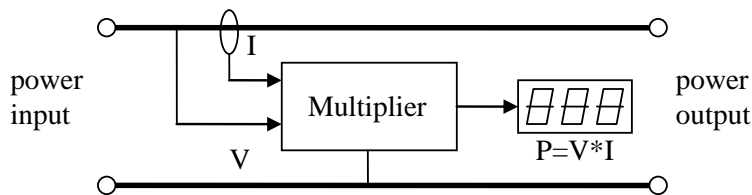

Figure 1 Power meter functional diagram. The power meter consists of circuitry that measures the voltage across and the current through a pair of wires, multiplies them together, and then displays the **instantaneous power** ($V \cdot I$).

Figure 2 shows the top view of the power meter that is used in this lab. The meter is built on a printed circuit board (PCB) without a chassis. As shown, there are two pairs of wiring connections near the front edge of the Power Meter board. One pair of the connections (on the left side) should be connected to the *source* of the energy and the other pair should be connected to the circuit that uses energy (the *load* side). The designation of ‘source’ on the left and ‘load’ on the right is only for reference. The actual connections are not critical. If the power flow is from the left connections to the right connections, the display will show a positive power reading. If the power flow is in the other direction, it will show a negative number. In fact, in some applications, the power flow direction changes with time.

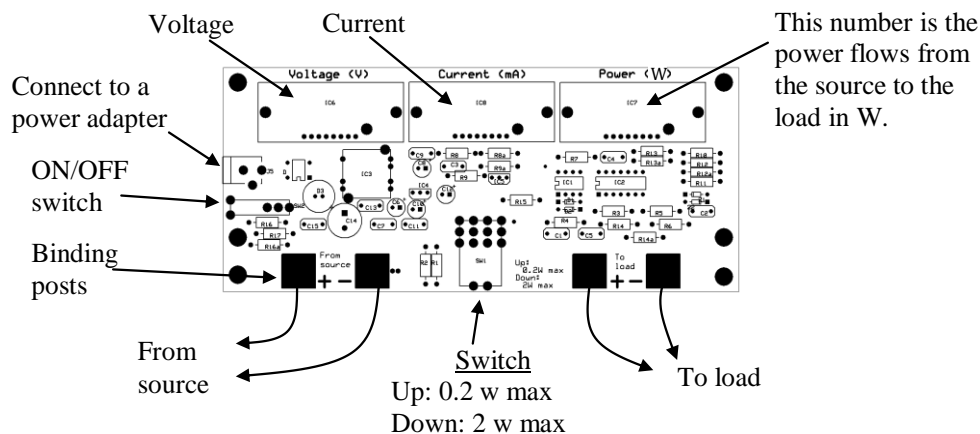

Figure 2 Top view of the power meter. Note that you must connect a DC adapter at the left side to power the meter.

As shown in Figure 2, the first digital display on the left shows the **voltage** across the wires (the connections) and the center display shows the **current** through the wires (from the left connections to the right connections). The far right display shows the **power** in Watts (W). The switch (located between the connections) changes the metering range from 0.2 W maximum to 2 W maximum. Your wind turbine will most likely generate more than 2 W. If this is the case, the switch should be in the 2W maximum setting (down position) for this experiment.

The hardware for facilitating the wire connection is called a ‘binding post’ (see Figure 3).

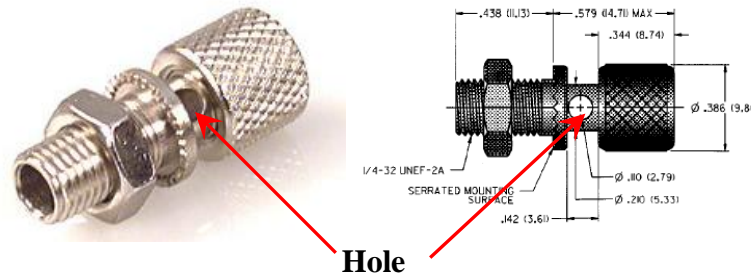

Figure 3 Binding Post. A binding post has a hole through which you insert the wire you wish to connect and tighten the cylindrical knob to make good electrical contact.

To make a wire connection to the binding post, you first unscrew the top cylindrical knob to expose the hole on the post. You insert the wire through the hole (or you can loop the wire around the post). You then tighten the knob so that it presses down on the wire. Do not unscrew the knob so that it comes off the post and do not screw down too hard and cut off the wire.

Load Box

Figure 4 shows the load box that will be used in the lab. The load box consists of a bank of LEDs and a Potentiometer (POT) that allows you to control the amount of power to LEDs (i.e., the amount of loading to the wind turbine generator) by turning the knob. The LEDs will get brighter if more power is drawn from the generator.



Figure 4 Load Box. LEDs are used as the load for the wind turbine. A POT is used for adjusting the amount of loading to the wind turbine generator.

Wind Turbine Power Measurement

For any electrical power source (such as a wind turbine generator), there is a maximum power that the source can provide (see lecture notes). Whether this maximum power is fully utilized (or drawn) from the generator depends on the loading condition. Regardless of the wind condition or turbine design, there is little or no power from the generator if, for example, the resistance is so low that the voltage is completely loaded down (zero voltage) or resistance is so high that no current flows (zero current). Why? (Hint: how is power related to voltage and current?)

The goal of this experiment is to determine the maximum output power of your wind turbine generator. To do so, you must search for the best loading condition by varying the resistance on the circuit. For a wind turbine generator, the best loading condition varies with wind speed (we do not explore this relationship in this lab). In a real wind turbine, a computer controlled power unit constantly adjusts the loading condition based on the wind speed in order to achieve the maximum possible power production under all conditions at all time.

Procedure:

1. Take your wind turbine/generator to a 'wind station' setup in the lab, and connect it to the power meter and the load box as shown in Figure 5. **DO NOT TURN ON THE BLOWER AT THIS TIME.** Connect your generator to the 'Source' side of the power meter by using two alligator clips as shown in Figure 5. The polarity of either connection is not important. If, for example, you connect the positive voltage from your turbine generator to the negative binding post, the voltage and the current readings will both be shown as a negative value. The power reading in this case, however, will remain positive.

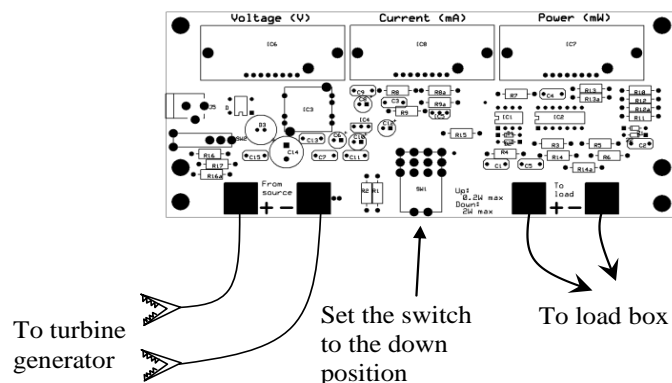

Figure 5. Wiring diagram for wind turbine power testing. Connect your wind turbine generator leads to the alligator clips, and connect the load box to the binding posts for the load.

2. Stick a small piece of reflective tape (provided) on one of your turbine blades (on the hub, where it is stronger). The blades are fragile, so don't put too much pressure on them.
3. Before you turn on the blower, assign each team member to one of the following tasks:
 - One team member controls the load box.
 - One team member operates the non-contact tachometer.
 - One team member records the experimental data (wind speed, RPM, voltage, current, and power readings)

- One team member turns on/off the blower, measures wind speed, and secures your turbine during the experiment.
 - Everyone should wear safety goggles and stay out of the plane of turbine blade rotation (and keep bystanders out too).
4. BEFORE you position your turbine in the path of the wind, the ‘blower operator’ can turn on the blower (set it to ‘high’), and use an anemometer to determine the distance away from the outlet of the blower where the **wind speed is 25 MPH**. Record this distance.
 5. **TURN OFF THE BLOWER**, and then position your wind turbine at the distance determined in the previous step.
 6. Put the toggle switch to 1 Ω load.
 7. Turn on the blower (set the selection switch on the side of the blower to ‘high’).
 8. When the turbine reaches a steady state spinning speed, record the voltage, the current, the power, and the rotational speed of the turbine. This will serve as your baseline load for comparison.
 9. Now turn the big knob counterclockwise until it stops. This represents the minimum load (or maximum resistance) you can apply to the system. Change the toggle switch to “variable load” and when the turbine reaches a steady state spinning speed record the voltage, the current, the power, and the rotational speed of the turbine.
 10. Turn the knob clockwise a small amount (adjust the POT), and when the turbine reaches a steady state spinning speed record the voltage, the current, the power, and the rotational speed of the turbine.
 11. Repeat step 10 until you have turned the knob all the way clockwise.
 12. Your data should show a peak power point similar to the graph shown in Figure 6. Fig. 6 shows six data points, but you may have more.

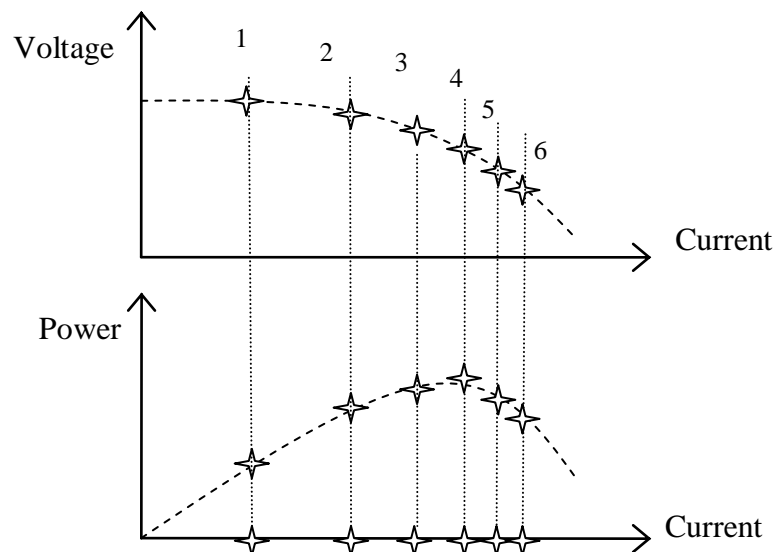

Figure 6. Voltage vs. Current and Power vs. Current plots. As resistance is decreased more current is drawn from the wind turbine generator but the generator output voltage will be loaded down. The output power peaks at a certain loading condition.

NOTE:

- To measure speed of the turbine, stand a foot or so behind your turbine, point the tachometer at the blades, and press the button on the side of the unit. You should see a red dot where the beam from the tachometer reflects off of the turbine blades. Make sure that you point the red dot at a spot where the reflective tape passes through. Note that, if you point the red dot elsewhere on the spinning turbine or did not put the reflective tape on, you will need to divide the RPM reading shown on the tachometer display by the number of blades to get the rotational speed of the generator. The blades are fragile. Be very careful not to put too much pressure on them when you put on the tape.
- After adjusting the POT wait for the turbine speed to stabilize before you take down the measurement. Ask your lab instructor or lab assistant to certify the maximum power that your turbine can generate.
- If the power curve continues to increase when the POT is turned all the way clockwise (i.e., no peak reading is observed), you can connect another load box in parallel with the one you are using so that additional load can be added to the generator.
- Fluctuations in the power meter readings are normal.
- The power reading should be the product of the voltage and current (verify this). Due to the measurement fluctuation, this relationship may not be exact according the readings.