

Available MSME projects

ME295A/ME299-I for Fall 2020

MSME project orientation meeting, 4/17/2020

Department of Mechanical Engineering, SJSU



Prof. Feruza Amirkulova, feruza.amirkulova@sjsu.edu

- Research Interests: Acoustic and elastic wave propagation and scattering, metamaterials, "invisibility" cloak, dynamic material characterization
- Available projects: https://sjsu.zoom.us/rec/share/uMtLAp7ctUFLYs-T7VzjAe19HrTueaa8hCdLq6ENy08PIHHgn06rK_auYa1esUDB (Access Password: msme2020!)



Prof. Buff Furman, burford.furman@sjsu.edu

- Research Interests: Precision machine design, mechatronic systems, mechanical measurement
- Available projects: https://sjsu.zoom.us/rec/share/_MIVDu2hzE1IQKvt7HnCC7RxQ73qT6a82yEYrKBenkcCVLSbcXiDfgVQWLCHLRZz (Access Password: msme2020!)



Prof. Winncy Du, winncy.du@sjsu.edu

- Research Interests: Mechatronics, robotics, machine vision, pattern recognition
- Available projects: https://sjsu.zoom.us/rec/share/-811JOH96kJobK_G6wbVXbUZEMPjaaa81SEfq6EPzh1oPjNaAA16IMyWDIX0StkL (Access Password: c2^*9747)



Prof. Nicole Okamoto, nicole.okamoto@sjsu.edu

- Research Interests: heat transfer, HVAC, thermal management of electronic systems
- Available projects: <https://sjsu.zoom.us/rec/share/6NNJLZ3M0I9LW7eWsXPRfJcrFdvdeaa81CdlrqYPmh0XTYDDu8HAKsk1MeYY-PW4> (Access Password: msme2020!)



Prof. Crystal Han, crystal.m.han@sjsu.edu

- Research Interests: Application of microfluidics in biotechnology, on-chip diagnosis, sample purification, electrokinetics
- Available projects: <https://sjsu.zoom.us/rec/share/tMIXfpbd-SBLTYWUygLEZoMKAAaPieaa82nJN-vQJzUsRw6LQWJ2AoIJ-XKIIhT7I> (Access Password: msme2020!)



Prof. Farzan Kazemifar, farzan.kazemifar@sjsu.edu

- Research Interests: Experimental thermal and fluid sciences, optical and laser-based diagnostic techniques, multiphase flow and transport in porous media, particle-based fluid velocity measurement techniques.
- Available projects: https://sjsu.zoom.us/rec/share/tOUsDJevsWdIRJ3UtWrxXPZmQoLGeaa813IWq_dbzEcxyx8pU3tTefTXiT-eYKyb (Access Password: msme2020!)



Prof. Amir Armani, amir.armani@sjsu.edu

- Research Interests: Design and Optimization, Additive Manufacturing, Structural Ceramics, Functionally Graded Materials, Smart Structures, and Sheet Metal Forming
- Available projects: https://sjsu.zoom.us/rec/share/xvZJMZLrzWJJZqP1uUryS_UIP6m-X6a8gXQd-foEzkhv_YThdh9J38GKi_qSTwMX (Access Password: msme2020!)



Prof. Vimal Viswanathan, vimal.viswanathan@sjsu.edu

- Research Interests: engineering design, new product development, design creativity and innovation, mechatronics systems design
- Available projects: https://sjsu.zoom.us/rec/share/wuxol-H3zl9IeNLz7UjUXqkPGaL8aaa8hyVM_PQInR404myagWEaMhvCH2Lu7dRm (Access Password: msme2020!)



Prof. Raymond Yee, raymond.yee@sjsu.edu

- Research Interests: mechanical design, materials behavior, fracture mechanics, FEA/CAD, stress analysis
- Available projects: see slides below



Prof. John Lee, sang-joon.lee@sjsu.edu

- Research Interests: MEMS, microfluidics, microfabrication processes
- Available projects: link to be updated



Prof. Fred Barez, fred.barez@sjsu.edu

- Research Interests: electronics packaging, magnetic recording, fiber optics
- Available projects: see slides below



Prof. Saeid Bashash, Saeid.Bashash@sjsu.edu

- Research Interests: Control Systems, Mechatronics, Power and Energy Systems, Internet of Things
- Available projects: see slides below



Prof. Tai-ran Hsu, tai-ran.hsu@sjsu.edu

- Research Interests: MEMS design & packaging, thermomechanics, fracture mechanics
- Available projects: see slides below

3 MSME Research Projects

Mechanical Engineering Department

ME295A

for Fall 2020

Professor Raymond K. Yee

Parametric Study of Metal 3D Printing Processes

Additive Manufacturing (AM) technology for metal parts also commonly known as “Metal 3D Printing” has been received a lot of attentions in recent years. Many industry sectors such as biomedical field and aerospace would like to use this technology for their applications, the AM process control and its effects on fabricated parts have not been well understood. It has been observed that AM metal parts have a number of material abnormalities such as lack of fusion, porosities, and micro-cracks formation from the process and its residual stress produces permanent deformation (distortion) upon release from the platform.

In a typical AM process, laser or electron-beam is used as a heating source to fuse metal powders together to form the geometry of a part. Several key AM process parameters such as metal powder feed rate, heat source power, heat source travel speed, heat spot size, travel pattern, and substrate temperature etc. may have strong influence on microstructure variability, material abnormalities, and strength of a fabricated part.

Project Objectives:

- To perform a parametric study of key AM process parameters (using finite element simulation)
- To quantify their effects on residual stresses and/or deformation in a simulated part.
- To identify the optimal process parameter values for titanium/stainless steel 3D printing
- To fabricate relevant samples, examine microstructural defects, examine part distortion and perform mechanical testing to characterize its performance (Experimental Study)

Knowledge Requirements:

- (1) FEM (ANSYS), Thermal-mechanical interaction process.
- (2) Fabrication, mechanical testing and sample characterization.



Metal 3D Printer (Sample)



Metal 3D print samples
Projects by Prof. Yee
raymond.yee@sjsu.edu

Collapsible Cup Design Refinement & Analysis

Objective: To develop a portable and collapsible cup for hot & cold beverages (coffee, tea etc.)

Functional requirements: [Key features in design are highlighted in CAD]
Compact, reusable, 12 oz size, machine-washable, keep hot/cold drinks for at least 2hrs, eco-friendly, leak-proof, with magnetic locking.

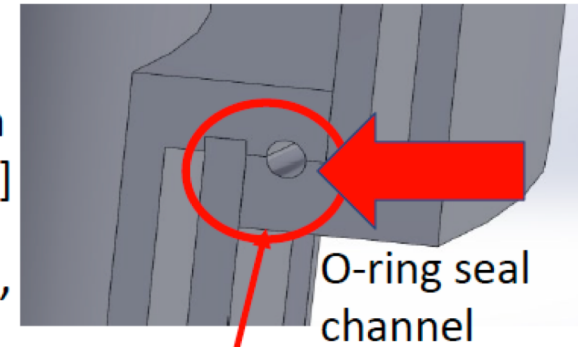

Project goals: Refine the existing design and perform transient thermal and O-ring fatigue analyses to achieve functional req'ts and specify its manufacturing.

Knowledge requirements: (1) Thermal simulation and fatigue evaluation. (2) manufacturing methods

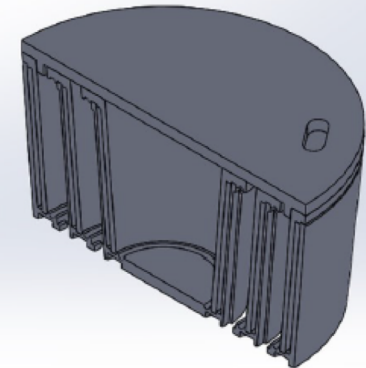
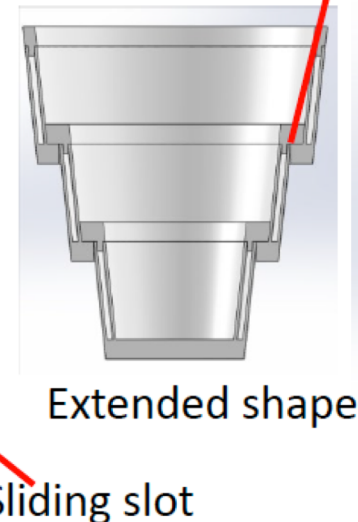
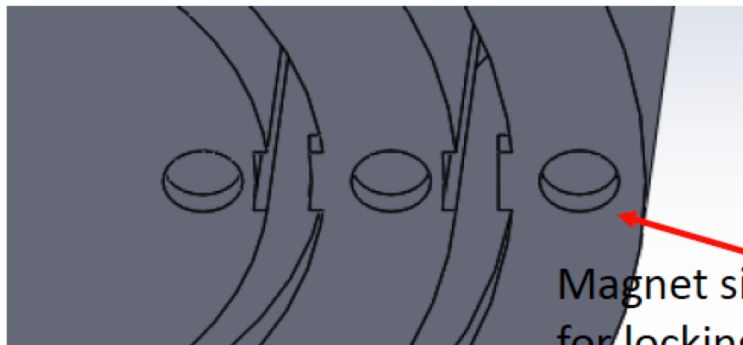

Crash Test Study Project (Industry sponsored)

High strain-rate deformation study

ATD Sled Experimental data for Numerical Simulation

Background: Calibration and verification of numerical models of Crash Test Dummy models, referred to as an anthropomorphic test device (ATD) is critical to using simulation for design of vehicles. There are many different size models to represent people based upon size. The 50th Percentile Hybrid III Male ATD is a standard model used for vehicle design both for personal and military vehicles. The IMPETUS 50th Percentile Hybrid III Male ATD has been verified for crash using the SAE J2856 automotive tests. Recently, the National Institute for Aviation Research (NIAR) provided the company with experimental data for a sled test that they performed with a Male ATD physical dummy. The project includes analyzing the experimental data and development of the corresponding numerical model of the sled test in conjunction with the IMPETUS ATD Model within the FE Program. The final report will be included in the documentation for the IMPETUS ATD.

Main Tasks:

- Literature research on ATD's, sled tests and Explicit Finite Element.
- Study experiments from National Institute for Aviation Research.
- Develop FE Model of the applied sled test set-up at NIAR.
- Verification of the IMPETUS ATD for sled tests. Inverse engineering of material constants if needed.



The student will learn about the IMPETUS Solver, Study Experimental Techniques and spend some time at CertaSIM's Saratoga Office to learn more about simulation technology.

San Jose State University, Professor R. Yee, Ph.D.

CertaSIM, LLC, M. R. Jensen, Ph.D.

MS Project and Thesis

Proposed Topics by Dr. Fred Barez

1/3

Vehicles:

1. Design of an all-wheel steering system for improved maneuverability
2. Active driver monitoring and alert system using machine learning
3. Vehicle cabin noise reduction for passenger comfort
4. Cone of Silence: Sound directionality on-demand
5. Vehicle fuel consumption efficiency through wheel hubcap design

Electronics Packaging:

1. Thermal management of smart poles used in street vehicle connectivity
2. Thermal property characterization of 3D printed polymers
3. Thermal property characterization of plastic resins at low pressure

Projects by Prof. Barez
fred.barez@sjsu.edu

MS Project and Thesis

Proposed Topics by Dr. Fred Barez

2/3

Autonomous Driving:

1. Design of a vehicle lane keeping and lane departure techniques
2. Design of an autonomous utility vehicle
3. Performance evaluation of solid state Radars and laser-based Lidars
4. Effects of vehicle charging station utilization on the grid

Design:

1. Design of a swivel, stowed away seat for mini vans
2. Application of exoskeleton techniques for an injury-free a production environment
3. Development of a Virtual Reality tool sets for Manufacturing 4.0

Projects by Prof. Barez
fred.barez@sjsu.edu

MS Project and Thesis
Proposed Topics by Dr. Fred Barez

3/3

Biomechanics and Health Care:

1. Application of wearable devices for human health monitoring and diagnostics
2. Design of simple and affordable ventilators

MS Projects for Fall 2020

Professor Saeid Bashash

1 or 2 spots for projects related to control systems

Projects by Prof. Bashash
saeid.bashash@sjsu.edu

Two MS Projects Offered by Professor T.R. Hsu for Fall 2019

Specialty: Green technologies. Contact E-mail: Prof. Tai-Ran Hsu at: tai-ran.hsu@sjsu.edu

Topic 1: On the Sustainability of Electric Vehicles:

This project involves “paper research” only. It is on a critical issue of whether electric vehicles (EVs) are indeed the ultimate solution to environmentally sustainable means for (urban) ground transportation.

Many perceive EVs to be eco-environmentally sustainable because they are free of emissions of toxic and greenhouse gases to the environment.

However, hasty replacing gas-powered vehicles by EVs will prompt sudden boost in demands for electricity generations, with approximate 60% of the e-power generated by fossil fuels in this country today.

The present project will update the statistical data in an unpublished paper presented by Prof. Hsu in an invited presentation in 2013 [1]. It will also investigate the impacts of converting almost all gas-powered vehicles to electricity-driven vehicles as advocated by several countries in the world. For instance, The Chinese government and the Swedish auto maker, Volvo company have announced that they will stop producing gas-powered vehicles after year 2040.

This research will also involve the negative environmental impact of **another** major contributor to the climate change that involves using electricity in producing millions of batteries that would be required to power EVs, and the eco-environmental impacts of recycling vast number of the spent batteries of the EVs.

To justify it a 2-semester project, the student will also offer his (her) outlook on the required electricity generated by clean renewable energies, such as solar and wind power for all EVs in 2040.

[1] Hsu, T.R. “On the Sustainability of Electrical Vehicles,” Presented at the 2013 IEEE Green energy and systems conference, CSU at Long Beach, CA, November 25, 2013

**Projects by Prof. Hsu
tai-ran.hsu@sjsu.edu**

Project 2: Battery Management Systems for Mobile Devices-with special application to the ZEM vehicle [2]

The ZEM vehicle project is an ongoing senior design project. The last student group working on the ZEM vehicle project in 2017 left with the installment of a proper battery management system (BMS) involving TESLA battery packs unfinished in their prototype vehicle. The proposed project requires using this prototype for the student's BMS project.

This project involves the study of BMS specifically for mobile devices and machines such as: industrial Robots, EVs including automated guide vehicles (AGV) for automated manufacturing and warehouse operations, and large drones. This particular research area has become important aspects of the design of these mobile machines.

The proposed research project will begin with literature review of currently available technologies for the topical applications, to be followed by specific BMS for practical application to the three aforementioned devices. This project will end with the specific application of connecting the existing TESLA battery pack to the ZEM prototype vehicle in the lab (see the illustration below), and also with a review of prospect of future battery management system with possible AI and expanded applications such as deep-sea unmanned submarines.

Limited funds are available for this project.

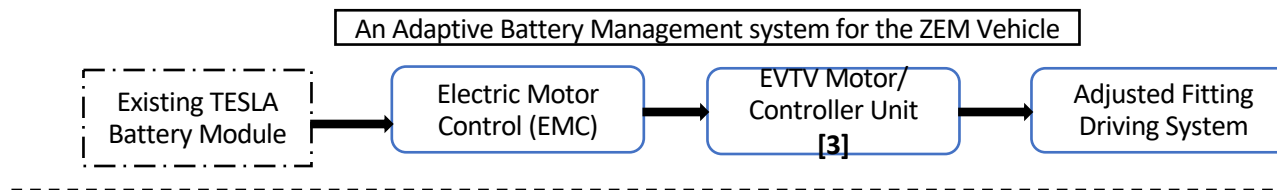

[2] Hsu, T.R., "Performance and Required E-Power Estimate for High Performance ZEM Vehicle," Internal document, 2016

[3] "EVTV Motor/controller for TGESLA Model S Battery Modules, June 2017